



## **Section 6**

# **Industrial & Commercial Runoff Management Practices (ICPs)**

---



## Section 6 – Industrial & Commercial Runoff Management Practices (ICP)

### Introduction

This section presents the BMP fact sheets for Industrial & Commercial Runoff Management Practices (ICPs). ICPs predominately focus on practices relating to manufacturing facility “Good Housekeeping” measures with a special emphasis on hazardous materials. Other frequently used practices that address containing or capturing pollutants from vehicle and equipment maintenance and repair, fueling, washing, minor construction and other activities are also included.

### Management Practice Fact Sheets

This section contains the following BMP fact sheets.

Industrial & Commercial Runoff Management Practice Fact Sheets			
Fact Sheet ID	Description	Fact Sheet ID	Description
ICP – 01	Non-Stormwater Discharges to Storm Drains	ICP – 07	Outdoor Process Equipment Inspections and Maintenance
ICP – 02	Vehicle and Equipment Fueling	ICP – 08	Waste Handling and Disposal
ICP – 03	Vehicle and Equipment Washing and Cleaning	ICP – 09	Contaminated or Erodible Surface Areas
ICP – 04	Vehicle and Equipment Maintenance and Repair	ICP – 10	Building and Grounds Construction and Maintenance
ICP – 05	Outdoor Loading/Unloading	ICP – 11	Over-Water Activities
ICP – 06	Outdoor Container Storage of Liquids	ICP – 12	Employee Training

Each fact sheet has a quick reference guide indicating what pollutant constituents the BMP is targeting and implementation requirements. The BMPs presented in this section are intended to coincide with non-construction activity. Additional details are provided in the section covering Construction Management Practices (CP) for practices are that intended to be used during construction activities.



## Non-Stormwater Discharges to Storm Drains

ICP – 01



Hamilton County



Water Quality Program

### Description

Eliminate non-stormwater discharges to the stormwater collection system. Non-stormwater discharges may include oils, paints, acids, solvents, process wastewaters, cooling waters, wash waters, and sanitary wastewater. This task is intended to eliminate nutrients, heavy metals, toxic materials, floatable debris, oxygen demand substances, oil and grease, bacteria and virus.

### Approach

To ensure that the stormwater system discharge contains only stormwater, industry should:

- ❖ Locate discharges to the municipal storm sewer system or “Waters of the State” from the industrial storm sewer system from “as-built” pipeline schematics, and visual observation (walk boundary of plant site).
- ❖ Locate and evaluate all discharges to the industrial storm sewer system (including wet weather flows) from: “as-built” pipeline schematics, visual observation, dye tests, TV camera, chemical field test kits, and smoke tests.
- ❖ Develop a plan to eliminate illicit connections.
- ❖ Develop disposal options.
- ❖ Document that non-stormwater discharges have been eliminated by recording tests performed, methods used, dates of testing, and any on-site drainage points observed.

The following approaches may be used to identify non-stormwater discharges:

- ❖ Visual Inspection
  - The easiest method is to inspect each discharge point during dry weather.
  - Keep in mind that flow from a storm event can continue for three days or more and groundwater often infiltrates the underground stormwater collection system.
- ❖ Piping Schematic
  - The piping schematic is a map of pipes and stormwater systems used to carry wastewater, cooling water, sanitary wastes, etc.
  - A review of the “as-built” piping schematic is a way to determine if there are any connections to the stormwater collection system.
  - Inspect the path of floor drains in older buildings. It is not uncommon to



find cross-connections in older buildings.

- ❖ Smoke Testing
  - Smoke testing of wastewater and stormwater collection systems is used to detect connections between the two systems.
  - During dry weather the stormwater collection system is filled with smoke and then traced to sources. The appearance of smoke at the base of a toilet indicates that there may be a connection between the sanitary and the stormwater system.
  
- ❖ Dye Testing
  - A dye test can be performed by simply releasing a dye into either your sanitary or process wastewater system and examining the discharge points from the stormwater collection system for discoloration.

## Limitations

It can be difficult to locate illicit connections especially if there is groundwater infiltration.

Many facilities do not have accurate, up-to-date schematic drawings. Mistakes in construction may not be reflected in the schematics.

TV and visual inspections can identify illicit connections to the storm sewer, but further testing is sometimes required (e.g., dye, smoke) to identify sources.

Non-stormwater discharges to the stormwater collection system may include any water used directly in the manufacturing process (process wastewater), air conditioning condensate and coolant, non-contact cooling water, cooling equipment condensate, outdoor secondary containment water, vehicle and equipment wash water, sink and drinking fountain wastewater, sanitary wastes, or other wastewaters. Table ICP-12-1 presents disposal alternatives information for specific types of wastewaters.

## Additional Information

Substances illegally dumped on the street and into the storm drain system and creeks include paints, used oil and other automotive fluids, construction debris, chemicals, fresh concrete, leaves, grass clippings, and pet wastes. All of these wastes can cause stormwater and receiving water quality problems as well as clog the storm drain system itself.

## References

CDM et.al. for the California SWQTF, 1993. *California Storm Water Best Management Practice Handbooks, Industrial Handbook*.

CDM et.al. for the California Department of Transportation, 1997. *Caltrans Storm Water Quality Handbooks*.

SWRCB, 1992. *General Industrial Storm Water Permit*,.

SFBRWQCB, 1992. *NPDES General Permit for Discharges of Storm Water Associated with Industrial Activity in Santa Clara County to South San Francisco Bay or its Tributaries*.

USEPA, 1992. *Storm Water Management for Industrial Activities: Developing Pollution Prevention Plans, and Best Management Practices*, EPA 832-R-92-006.



## Vehicle and Equipment Fueling

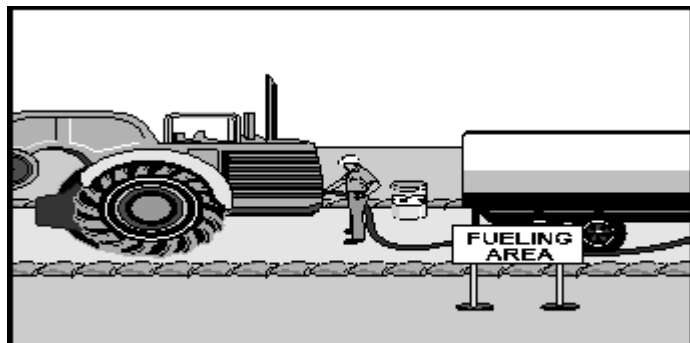

ICP – 02

Hamilton County



Water Quality Program

**Description** Prevent fuel spills and leaks, and reduce their impacts to stormwater. This management practice is likely to create a significant reduction in VOCs, heavy metals, toxic materials, and oil and grease.

**Approach** Spills from fueling or from the transfer of fuels to the storage tank can be a significant source of pollution. Fuels carry contaminants of particular concern to humans and wildlife, such as heavy metals, toxic materials, and oil and grease, which are not easily removed by stormwater treatment devices. Consequently, control at the source is particularly important. Adequate control can be achieved with careful design of the initial installation, retrofitting of existing installations, and proper spill control and cleanup procedures, as described below.

- ❖ Design the fueling area to prevent the run-on of stormwater and the runoff of spills:
  - Cover fueling area if possible.
  - If it is not possible to cover the fueling area, then route all stormwater runoff from the area to an oil/water separator. For permanent fueling areas, use an oil/grit separator (see TSS-11).
  - Use a perimeter drain or slope pavement inward with drainage to sump.
  - Pave fueling area with concrete rather than asphalt.
- ❖ Where covering is infeasible and the fuel island is surrounded by pavement, apply a suitable sealant that protects the asphalt from spilled fuels.
- ❖ If a dead-end sump is not used to collect spills, install an oil/water separator.
- ❖ Install vapor recovery nozzles to help control drips as well as air pollution.
- ❖ Discourage “topping-off” of fuel tanks.
- ❖ Place secondary containment around the fuel truck when it is transferring fuel to the storage tank. The truck operator should remain with the truck while the transfer is in progress.
- ❖ Place a stockpile of spill cleanup materials where it will be readily accessible.
- ❖ Use dry methods to clean the fueling area whenever possible. If you periodically clean by pressure washing, place a temporary plug in the downstream drain and pump out the accumulated water. Properly dispose of the water through the sanitary sewer system only after gaining permission from the Waste Water



Treatment Authority (WWTA) or Moccasin Bend Waste Water Treatment Plant.

- ❖ Use adsorbent materials on small spills and general cleaning rather than hosing down the area. Remove the adsorbent materials promptly.
- ❖ Carry out all Federal and State requirements regarding underground storage tanks, or install above ground tanks.
- ❖ Do not use mobile fueling of mobile industrial equipment around the facility; rather, transport the equipment to designated fueling areas.
- ❖ The Spill Prevention Control and Countermeasure (SPCC) Plan, which is required by law for some facilities, is an effective program to reduce the number of accidental spills. Keep your Spill Prevention Control and Countermeasure (SPCC) Plan up-to-date.
- ❖ Train employees in proper fueling and cleanup procedures including periodic review of the SPCC.
- ❖ For a quick reference on disposal alternatives for specific wastes, see Table ICP-12-1 in the Employee/Subcontractor Training BMP fact sheet.

## Maintenance

- ❖ Clean/empty oil/water separators at the appropriate intervals. Generally this is inspected monthly.
- ❖ Keep ample supplies of spill cleanup materials on-site.
- ❖ Inspect fueling areas and storage tanks on a regular schedule. Special attention should be given to detecting leaks to/from any underground storage tanks.

## Limitations

- ❖ Oil/water separators are only as effective as their maintenance program.
- ❖ The retrofitting of existing fueling areas to minimize stormwater exposure or spill runoff can be expensive. Good design must occur during the initial installation.
- ❖ Installing extruded curb along the “upstream” side of the fueling area to prevent stormwater run-on is a modest cost.

## Additional Information

### Design

With new installations, design the fueling area to prevent the run-on of stormwater and the runoff of spills. This can be achieved by contouring the site in the appropriate fashion. Covering the site is the best approach but may not be feasible if very large mobile equipment is being fueled. Stormwater run-on can be diverted around the fueling area by an extruded curb, berm, swale, or with a “speed bump”, if vehicle access is needed from this direction. Spills can be contained within the fueling area either by using a perimeter drain or by sloping the pavement inward with drainage to a sump. In both cases the drain can be connected to the storm drain with a valve that is only closed during fueling operations and left open at all other times. Pave the fueling area with Portland cement concrete rather than asphalt, since the latter will gradually disintegrate and be washed from the site.

### Mobile Fueling

If your facility has large numbers of mobile equipment working throughout the site and you currently fuel them with a mobile fuel truck, consider establishing a designated area for fueling. With the exception of tracked equipment such as bulldozers and perhaps small forklifts, most vehicles should be able to travel to a designated area with little lost time. Place temporary “caps” over nearby catch basins or manhole covers so that if a spill



occurs it is prevented from entering the storm drain.

## Primary References

*California Storm Water Best Management Practice Handbooks, Industrial Handbook*, CDM et.al. for the California SWQTF, 1993.

City of Seattle, 1989. *Water Quality Best Management Practices Manual*.

Santa Clara Valley Nonpoint Source Pollution Control Program, 1992. *Best Management Practices for Automotive-Related Industries*.

Santa Clara Valley Nonpoint Source Pollution Control Program, 1992. *Best Management Practices for Industrial Storm Water Pollution Control*.

USEPA, 1992. *Storm Water Management for Industrial Activities: Developing Pollution Prevention Plans, and Best Management Practices*, EPA 832-R-92-006.



## Vehicle and Equipment Washing & Cleaning

ICP – 03

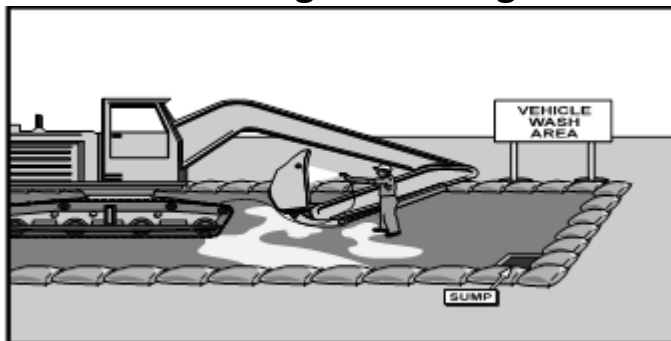

Hamilton County



Water Quality Program

### Description

Prevent or reduce the discharge of pollutants to stormwater from vehicle and equipment washing and steam cleaning. This practice is designed to address permanent washing and cleaning operations. This management practice is likely to create a significant reduction in sediment, nutrients, heavy metals, toxic materials, and oil and grease. For discussion of on-site or temporary washing and cleaning, see CP-12.

### Approach

- ❖ Use designated wash areas, preferably covered to prevent contact with stormwater and bermed with a continuous berm, double layered straw or sand bag barrier, or diversion swale to contain wash water.
- ❖ Discharge wash water to sanitary sewer, after contacting local sewer authority to find out if pretreatment (oil/water separators or other means) is required.
- ❖ Educate employees on pollution prevention measures including review of the Spill Prevention Control and Countermeasures (SPCC) plan.
- ❖ When cleaning vehicles/equipment with water:
  - Use as little water as possible. High pressure sprayers may use less water than a hose, and should be considered.
  - Use positive shutoff valve to minimize water usage.
- ❖ Consider filtering and recycling wash water.
- ❖ For a quick reference on disposal alternatives for specific wastes see Table ICP-12-1 in the Employee/Subcontractor Training BMP fact sheet.
- ❖ When the vehicle/equipment washing/cleaning operation cannot be located within a structure or building equipped with sanitary sewer facilities, the outside cleaning area should have the following characteristics:
  - Perimeter diversion swale or containment berm or barrier;
  - Located away from storm drain inlets, drainage facilities, or watercourses;
  - Paved with concrete or asphalt, or stabilized with an aggregate base;
  - Bermed to contain wash waters and to prevent run-on and runoff;
  - Configure wash area with a sump to allow collection and disposal of wash water;
  - Discharge wash water to a sanitary or process waste sewer (where permitted), or to a dead end sump. Wash waters should not be discharged to storm drains or watercourses;
  - Sloped for wash water collection to swale and/or diverted to sump; and
  - Discharge pipe should have a positive control valve that allows switching





between the storm drain and sanitary or process sewer, clearly designated and equipped with media infiltration or oil/water separator.

**Maintenance** Inspect berms for necessary repair and patching weekly. Regularly inspect and maintain sumps, oil/water separators, and on-site treatment/recycling units.

**Limitations** Steam cleaning can generate significant pollutant concentrations requiring permitting, monitoring, pretreatment, and inspections. The measures outlined in this fact sheet are insufficient to address all the environmental impacts and compliance issues related to steam cleaning. Do not use solvents to clean vehicles/equipment on site. Do not permit steam cleaning on site.

**Additional Information** Washing vehicles and equipment outdoors or in areas where wash water flows onto the ground can pollute stormwater. If your facility washes or steam cleans a large number of vehicles or pieces of equipment in an outdoor or uncovered facility, consider contracting out this work to a commercial business. These businesses are better equipped to handle and dispose of the wash waters properly. Contracting out this work can also be economical by eliminating the need for a separate washing/cleaning operation at your facility.

**References** CDM et.al. for the California SWQTF, 1993. *California Storm Water Best Management Practice Handbooks, Industrial Handbook.*

City of Seattle, 1989. *Water Quality Best Management Practices Manual.*

Santa Clara Valley Nonpoint Source Pollution Control Program, 1992. *Best Management Practices for Automotive-Related Industries.*

Santa Clara Valley Nonpoint Source Pollution Control Program, 1992. *Best Management Practices for Industrial Storm Water Pollution Control.*

USEPA, 1992. *Storm Water Management for Industrial Activities: Developing Pollution Prevention Plans, and Best Management Practices*, EPA 832-R-92-006.



## Vehicle and Equipment Maintenance & Repair

ICP – 04

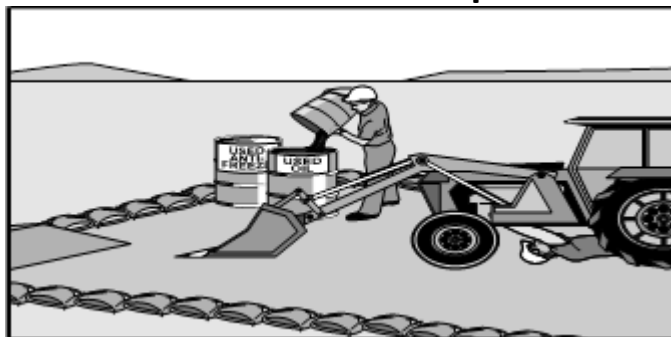

Hamilton County



Water Quality Program

### Description

Procedures and practices to reduce the discharge of pollutants to the storm drain system or to watercourses as a result of vehicle and equipment maintenance by conducting these activities off-site or in a designated area designed to contain spills and prevent run-on or runoff. This management practice is likely to create a significant reduction in heavy metals, toxic materials, and oil and grease.

### Approach

Vehicle or equipment maintenance is a potentially significant source of stormwater pollution. Activities that can contaminate stormwater include engine repair and service (parts cleaning, spilled fuel, oil, etc.), replacement of fluids, and outdoor equipment storage and parking (dripping engines). For further information on vehicle or equipment servicing, see ICP-02, Vehicle and Equipment Fueling, and ICP-03, Vehicle and Equipment Washing and Cleaning.

- ❖ Use centralized, covered, off-site maintenance facilities whenever practical.
- ❖ Locate on paved surfaces where practical (preferably paved with concrete rather than asphalt).
- ❖ Use berms to protect maintenance areas from run-on.
- ❖ Always use secondary containment, such as a drain pan or drop cloth, to catch spills or leaks when removing or changing fluids.
- ❖ Do not dump fuels and lubricants onto the ground.
- ❖ Do not place used oil in a dumpster.
- ❖ Place a stockpile of spill cleanup materials where it will be readily accessible.
- ❖ Do not bury used tires.
- ❖ Repair leaks of fluids and oil as soon as possible.
- ❖ Clean leaks, drips, and other spills with as little water as possible. Use rags for small spills, a damp mop for general cleanup, and dry absorbent material for larger spills. Use the following three-step method for cleaning floors:
  1. Clean spills with rags or other absorbent materials.
  2. Sweep floor using dry absorbent material.
  3. Mop floor. Mop water may be discharged to the sanitary sewer via a toilet or sink.
- ❖ Provide spill containment dikes or secondary containment (swales, berms, walls, etc.) around stored oil and chemical drums.



- ❖ Maintain an adequate supply of spill cleanup materials in designated areas.
- ❖ Inspect equipment for damaged hoses and leaky gaskets routinely. Repair or replace as needed.
- ❖ Keep equipment clean; don't allow excessive build-up of oil and grease.
- ❖ Keep drip pans or containers under the areas that might drip.
- ❖ Do not change motor oil or perform equipment maintenance in non-appropriate areas. Use a vehicle maintenance area designed to prevent stormwater pollution.
- ❖ Inspect stored equipment for leaks on a regular basis.
- ❖ Segregate liquid, solid and hazardous wastes for easier recycling and may reduce treatment costs. Keep hazardous and non-hazardous wastes separate, do not mix used oil and solvents, and keep chlorinated solvents (like 1,1,1-trichloroethane) separate from non-chlorinated solvents (like kerosene and mineral spirits). Many products made of recycled (i.e., refined or purified) materials are available. Engine oil, transmission fluid, antifreeze, and hydraulic fluid are available in recycled form. Buying recycled products supports the market for recycled materials.
- ❖ If possible, eliminate or reduce the amount of hazardous materials and waste by substituting non-hazardous or less hazardous materials. For example:
  - Use non-caustic detergents instead of caustic cleaning agents for parts cleaning (ask your supplier about alternative cleaning agents).
  - Use detergent-based or water-based cleaning systems in place of organic solvent degreasers. Wash water may require treatment before it can be discharged to the sewer. Contact your local sewer authority for more information.
  - Replace chlorinated organic solvents (1,1,1-trichloroethane, methylene chloride, etc.) with non-chlorinated solvents. Non-chlorinated solvents like kerosene or mineral spirits are less toxic and less expensive to dispose of properly. Check list of active ingredients to see whether it contains chlorinated solvents. The "chlor" term indicates that the solvent is chlorinated.
  - Choose cleaning agents that can be recycled.
  - Contact your supplier or refer to trade journals for more waste minimization ideas.
- ❖ Make sure incoming vehicles are checked for leaking oil and fluids.
- ❖ Clean yard storm drain inlet(s) regularly and especially after large storms.
- ❖ Do not pour materials down drains or hose down work areas; use dry sweeping. Infrequent steam or pressure wash is appropriate if wash water is collected and/or treated.
- ❖ Store idle equipment under cover.
- ❖ Drain all fluids from wrecked vehicles into pans or other containers instead of letting them drain on the ground.
- ❖ Recycle greases, used oil or oil filters, antifreeze, cleaning solutions, automotive batteries, hydraulic, and transmission fluids.
- ❖ Minimize use of solvents. Switch to non-toxic chemicals for maintenance when possible.
- ❖ Parts are often cleaned using solvents such as trichloroethylene, 1,1,1-trichloroethane or methylene chloride. Many of these cleaners are harmful and must be disposed of as a hazardous waste. Cleaning without using liquid cleaners (e.g. wire brush) whenever



possible reduces waste. Prevent spills and drips of solvents and cleansers to the shop floor. Do all liquid cleaning at a centralized station so the solvents and residues stay in one area. Locate drip pans, drain boards, and drying racks to direct drips back into a solvent sink or fluid holding tank for re-use.

- ❖ Reducing the number of solvents makes recycling easier and reduces hazardous waste management costs. Often, one solvent can perform a job as well as two different solvents.
- ❖ Be especially careful with wrecked vehicles, whether you keep them indoors or out, as well as vehicles kept on-site for scrap or salvage. Wrecked or damaged vehicles often drip oil and other fluids for several days.
  - As the vehicles arrive, place drip pans under them immediately, even if you believe that the fluids have leaked out before the car reaches your shop.
  - Build a shed or temporary roof over areas where you park cars awaiting repair or salvage, especially if you handle wrecked vehicles. Build a roof over vehicles you keep for parts.
  - Drain all fluids, including air conditioner coolant, from wrecked vehicles and “part” cars. Also drain engines, transmission, and other used parts.
- ❖ Paint signs on storm drain inlets to indicate that they are not to receive liquid or solid wastes.
- ❖ Oil filters disposed of in trashcans or dumpsters can leak oil and contaminate stormwater. Most municipalities prohibit or discourage disposal of these items in solid waste facilities. Place the oil filter in a funnel over the waste oil recycling or disposal collection tank to drain excess oil before disposal. Oil filters can be crushed and recycled. Ask your oil supplier or recycler about recycling oil filters.
- ❖ If the vehicle or equipment is to be stored outdoors, oil and other fluids should be drained first.
- ❖ There are several commercial available materials and devices that can temporarily seal (some magnetically) storm or sanitary drains. Place these in conspicuous locations proximate to the drains and train personnel in their use for spills and leaks.
- ❖ Store cracked batteries in a non-leaking secondary container. Do this with all cracked batteries, even if you think all the acid has drained out. If you drop a battery, treat it as if it is cracked. Put it into the containment area until you are sure it is not leaking.
- ❖ For a quick reference on disposal alternatives for specific wastes, see Table ICP-12-1 in the Employee/Subcontractor Training BMP fact sheet.
- ❖ Collect leaking or dripping fluids in fluid specific drip pans or containers. Fluids are easier to recycle if kept separate.
- ❖ Keep a drip pan under the vehicle while you unclip hoses, unscrew filters, or remove other parts. Use a drip pan under any vehicle that might leak while you work on it to keep splatters or drips off the shop floor.
- ❖ Promptly transfer used fluids to the proper waste or recycling drums. Don’t leave full drip pans or other open containers lying around.
- ❖ Train employees and subcontractors in proper maintenance and spill procedures. This should include periodic review of the Spill Prevention Control and Countermeasures (SPCC) Plan.

#### Maintenance

- ❖ Maintain waste fluid containers in leak proof condition.
- ❖ Vehicle and equipment maintenance areas shall be inspected regularly.



## Limitations

- ❖ Space and time limitations may preclude all work being conducted indoors.
- ❖ It may not be possible to contain and clean up spills from vehicles/equipment brought on-site after working hours.
- ❖ Drain pans (usually 1 ft. (0.3 m) x 1 ft. (0.3 m)) are generally too small to contain antifreeze, which may gush from some vehicles, so drip pans (3 ft. (0.91 m) x 3 ft. (0.91 m)) may have to be purchased or fabricated.
- ❖ Dry floor cleaning methods may not be sufficient for some spills. Use three-step method instead.
- ❖ Identification of engine leaks may require some use of solvents.

## References

CDM et.al. for the California SWQTF, 1993. *California Storm Water Best Management Practice Handbooks*, Industrial Handbook.

CDM et.al. for the California Department of Transportation, 1997. *Caltrans Storm Water Quality Handbooks*.

DTSC, 1988. *Hazardous Waste Reduction Assessment Handbook – Automotive Repair Shops*.

DTSC, 1988. *Hazardous Waste Reduction Checklist – Automotive Repair Shop*.

DTSC, 1989. Fact Sheet – *Waste Reduction for Automotive Repair Shops*.

G.S. Silverman, et. al, 1986 Environmental Professional, Vol. 8, pp 351-362. *Best Management Practices for Controlling Oil and Grease in Urban Storm Water Runoff*.

Santa Clara Valley Nonpoint Source Pollution Control Program, 1992. *Best Management Practices for Automotive-Related Industries*.

Santa Clara Valley Nonpoint Source Pollution Control Program, 1992. *Best Management Practices for Industrial Storm Water Pollution Control*.

USEPA, 1992. *Storm Water Management for Industrial Activities: Developing Pollution Prevention Plans, and Best Management Practices*, EPA 832-R-92-006.



## Outdoor Loading/Unloading of Materials

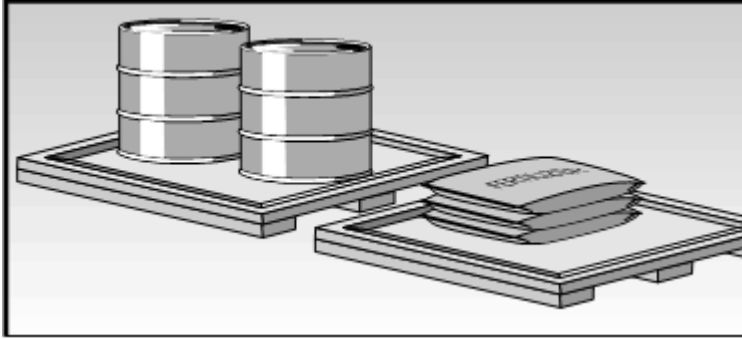

ICP – 05

Hamilton County



Water Quality Program

### Description

Prevent or reduce the discharge of pollutants to stormwater from outdoor loading/unloading and storage of materials by enclosing or covering materials, installing secondary containment, and preventing stormwater run-on. This management practice is likely to create a significant reduction in nutrients, heavy metals, toxic materials, oxygen demanding substances, and oil and grease.

### Approach

- ❖ The loading/unloading of materials usually takes place outside. Loading or unloading of materials occurs in two ways: Materials in containers or direct liquid transfer. Materials spilled, leaked or lost during loading/unloading may collect in the soil or on other surfaces and be carried away by runoff or when the area is cleaned. Rainfall may wash pollutants from machinery used to unload or move materials. The loading or unloading may involve rail or truck transfer.
- ❖ The most important factors in preventing these constituents from entering stormwater is:
  - Limit exposure of material to rainfall.
  - Prevent stormwater run-on.
  - Check equipment regularly for leaks.
  - Contain spills during transfer operations.
- ❖ Loading or unloading of liquids should occur in the manufacturing building so that any spills that are not completely retained can be discharged to the sanitary sewer, treatment plant, or treated in a manner consistent with permit requirements.

### Training

- ❖ Train employees and subcontractors on the proper material delivery and storage practices including review of the Spill Prevention, Control and Countermeasures (SPCC) Plan.
- ❖ Make sure fork lift operators are properly trained to limit spills or damaged containers.
- ❖ Employees should be periodically trained to be well acquainted with the Material Safety Data Sheets. They should be aware of material content, potential hazards to mixing with other materials stored on-site, and safety procedures required in the event of a spill or leak.

### Material Delivery Practices

- ❖ Keep an accurate, up-to-date inventory of material delivered and stored on site.



- ❖ Train all “exposed” employees in emergency spill clean-up procedures should they be present when dangerous materials or liquid chemicals are unloaded.
- ❖ Park tank trucks or delivery vehicles so that spills or leaks can be contained with drip pans under hoses or other secondary containment.
- ❖ Cover the loading/unloading docks to reduce exposure of materials to rain.
- ❖ Place a seal or door skirt between trailer and building to prevent exposure to rain.
- ❖ Design loading/unloading area to prevent stormwater run-on:
  - With diversion grading, berms or swales, and
  - Position roof downspouts to direct stormwater away from loading/unloading areas.
- ❖ Look for dust or fumes during loading or unloading operations.
- ❖ When loading and unloading tank trucks to above and below ground storage tanks, the following procedures should be used:
  - The area where the transfer takes place should be paved. If the liquid is reactive with the asphalt, Portland cement concrete should be used to pave the area.
  - Transfer area should be designed to prevent run-on of stormwater from adjacent areas. Sloping the pad and using a curb, like a speed bump, around the uphill side of the transfer area should reduce run-on.
  - Transfer area should be designed to prevent runoff of spilled liquids from the area. Sloping the area to a drain should prevent runoff. The drain should be connected to a dead-end sump or to the sanitary sewer if given approval by the local sewer authority. A positive control valve should be installed on the drain.
- ❖ For transfer from rail cars to storage tanks that must occur outside, use the following procedures:
  - Drip pans should be placed at locations where spillage may occur, such as hose connections, hose reels, and filler nozzles. Use drip pans when making and breaking connections.
  - Drip pan systems should be installed between the rails to collect spillage from tank cars.

#### ***Material Storage Areas and Practices***

- ❖ Designate storage areas at the project site with conspicuous signs and employee training.
- ❖ Store materials indoors within existing structures or sheds when available.
- ❖ Have proper storage instructions posted at all times in an open and conspicuous location.
- ❖ Locate the storage area away from the storm drain system and watercourses.
- ❖ Prevent spills or leakage of liquid materials from contaminating soil or soaking into the ground by placing storage areas on impervious surfaces.
- ❖ Provide curbs or dikes around the perimeter of material storage areas to prevent run-on from adjacent areas as well as runoff of stormwater from the material storage areas.
- ❖ Minimize the hazardous material inventory stored on site. Attempt to store only the volume of materials needed before another delivery is possible. Schedule more



- ❖ frequent deliveries of less material.
- ❖ Do not store hazardous chemicals, drums, or bagged materials directly on the ground. Place these items on a pallet under cover and when possible, in secondary containment.
- ❖ Parking lots or other surfaces near bulk materials storage areas should be swept periodically to remove debris blown or washed from storage area.
- ❖ Install pellet traps at stormwater discharge points where plastic pellets are loaded and unloaded.
- ❖ Keep hazardous chemicals in their original containers and keep them well labeled.
- ❖ Keep ample supply of storm drain seals near drains and inlets.
- ❖ Keep ample supply of appropriate spill clean-up material near storage areas.

### ***Spill Clean-up***

- ❖ Contain and clean up any spill immediately according to the SPCC Plan.
- ❖ Different materials pollute in different amounts. Make sure that each employee knows what a “significant spill” is for each material they use, and what is the appropriate response for “significant” and “insignificant” spills. A significant spill should be defined after review of the Materials Safety Data Sheet or other descriptive documentation that presents the contents and proper handling procedures.

### ***General Measures***

- ❖ Hazardous materials and wastes should be stored in covered containers and protected from vandalism.
- ❖ Place a stockpile of spill cleanup materials where it will be readily accessible.
- ❖ Train employees in spill prevention and cleanup procedures for the site.
- ❖ Educate employees and subcontractors on potential dangers to humans and the environment from spills and leaks.
- ❖ Hold regular meetings to discuss and reinforce appropriate disposal procedures (incorporate into regular safety meetings).
- ❖ Establish a continuing education program to indoctrinate new employees.
- ❖ Designate a foreman or supervisor to oversee and enforce proper spill prevention and control measures.

### ***Cleanup***

- ❖ Clean up leaks and spills immediately.
- ❖ On paved surfaces, clean up spills with as little water as possible. Use a rag for small spills, a damp mop for general cleanup, and absorbent material for larger spills. If the spilled material is hazardous, then the used cleanup materials are also hazardous and must be sent to either a certified laundry (rags) or disposed of as hazardous waste.
- ❖ Never hose down or bury dry material spills. Clean up as much of the material as possible and dispose of properly. See the waste management BMPs in this section for specific information.
- ❖ Minor Spills
  - Minor spills typically involve small quantities of oil, gasoline, paint, etc. which can be controlled by the first responder at the discovery of the spill.
  - Use absorbent materials on small spills rather than hosing down or burying the spill.
  - Remove the absorbent materials promptly and dispose of properly.
  - The practice commonly followed for a minor spill is:





1. Contain the spread of the spill.
2. Recover spilled materials.
3. Clean the contaminated area and/or properly dispose of contaminated materials.

❖ Significant/Hazardous Spills

- For significant or hazardous spills that cannot be controlled by personnel in the immediate vicinity, the following steps shall be taken:
  1. Notify the local emergency response by dialing 911. In addition to 911, the contractor will notify the proper officials. It is the contractor's responsibility to have all emergency phone numbers at the construction site.
  2. Notify the Engineer immediately and follow up with a written report.
  2. For spills of state reportable quantities or into a waterbody or adjoining shoreline, the contractor shall notify the TDEC – Department of Water Pollution Control at (423) 634-5745.
  3. For spills of federal reportable quantities or into a waterbody or adjoining shoreline, the contractor shall notify the National Response Center at (800) 424-8802.
  4. Notification should first be made by telephone and followed up with a written report.
  5. The services of a spills contractor or a Haz-Mat team shall be obtained immediately. Construction personnel should not attempt to clean up until the appropriate and qualified staff has arrived at the job site.
  6. Other agencies which may need to be consulted include, but are not limited to, the Fire Department, the Public Works Department, the City/County Police Department, OSHA, etc.

See CP-13 and 14 for details about spill prevention and control while maintaining or fueling vehicles and equipment.

**Maintenance**

- ❖ Inspect storage areas before and after rainfall events, and at least weekly during other times.
- ❖ Inspect to ensure that designated storage areas are kept clean and well organized.
- ❖ Repair and/or replace perimeter controls, containment structures, and covers as needed to keep them properly functioning.
- ❖ Conduct regular inspections to identify repairs necessary. The frequency of repairs will depend on the age of the facility.
- ❖ Check loading and unloading equipment regularly for leaks:
  - valves,
  - pumps,
  - flanges, and
  - connections.

**Limitations**

- ❖ Space limitation may preclude indoor storage.
- ❖ Storage sheds must meet building & fire code requirements.
- ❖ Space and time limitations may preclude all transfers from being performed indoors or under cover.



- ❖ It may not be possible to conduct transfers only during dry weather.

## References

CDM et.al. for the California SWQTF, 1993. *California Storm Water Best Management Practice Handbooks, Industrial Handbook.*

CDM et.al. for the California Department of Transportation, 1997. *Caltrans Storm Water Quality Handbooks,*.

City of Seattle, 1989. *Water Quality Best Management Practices Manual.*

Santa Clara Valley Nonpoint Source Pollution Control Program, 1992. *Best Management Practices for Industrial Storm Water Pollution Control.*

USEPA, 1992. *Storm Water Management for Industrial Activities: Developing Pollution Prevention Plans, and Best Management Practices*, EPA 832-R-92-006.

Santa Clara Valley Nonpoint Source Pollution Control Program, 1992. *Blueprint for a Clean Bay-Construction-Related Industries: Best Management Practices for Storm Water Pollution Prevention.*

*Storm Water Management for Construction Activities: Developing Pollution Prevention Plans and Best Management Practices*, EPA 832-R-92005; USEPA, April 1992.



## Outdoor Container Storage of Liquids

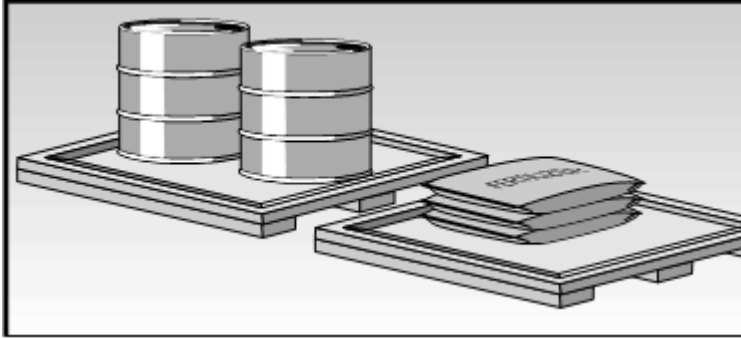

## ICP – 06

### Hamilton County



### Water Quality Program

#### Description

Prevent or reduce the discharge of pollutants to stormwater from outdoor container storage areas by installing safeguards against accidental releases, installing secondary containment, conducting regular inspections, and training employees in standard operating procedures and spill cleanup techniques. This management practice is likely to create a significant reduction in heavy metals, toxic materials, and oxygen demanding substances.

#### Approach

- ❖ All approaches mentioned in ICP-05 Outdoor Loading/Unloading of Materials are applicable to ICP-06 Outdoor Container Storage of Liquids. This fact sheet provides additional detail for storage of liquids.
- ❖ Accidental releases of materials from aboveground liquid storage tanks, drums, and dumpsters present the potential for contaminating stormwater with many different pollutants. Materials spilled, leaked or lost from storage containers and dumpsters may accumulate in soils or on the surfaces and be carried away by stormwater runoff. These source controls apply to containers located outside of a building used to temporarily store liquid materials. It should be noted that the storage of reactive, ignitable, or flammable liquids must comply with fire codes.
  - The most common causes of unintentional releases:
    - External corrosion and structural failure,
    - Installation problems,
    - Spills and overfills due to operator error,
    - Failure of piping systems (pipes, pumps, flanges, couplings, hoses, and valves),
    - Leaks during pumping of liquids or gases from truck or railcar to a storage facility or vice versa.
- ❖ Protect materials from rainfall, run-on, runoff, and wind dispersal:
  - Store materials indoors.
  - Cover the storage area with a roof.
  - Minimize stormwater run-on by enclosing the area or building with a berm.
  - Use “doghouse” for storage of liquid containers.
  - Use covered dumpsters for waste product containers.
- ❖ Storage of oil and hazardous materials must meet specific Federal and State standards including:
  - Spill Prevention Control and Countermeasure Plan (SPCC),



- secondary containment,
- integrity and leak detection monitoring, and
- emergency preparedness plans.
  
- ❖ Train operator on proper storage.
- ❖ Safeguards against accidental releases:
  - overflow protection devices to warn operator or automatic shutdown transfer pumps,
  - protection guards (bollards) around tanks and piping to prevent vehicle or fork lift damage, and
  - clear tagging or labeling, and restricting access to valves to reduce human error.
  
- ❖ Berm or surround tank or container with secondary containment system:
  - dikes, liners, vaults, or double walled tanks.
  
- ❖ Facilities with “spill ponds” designed to intercept, treat, and/or divert spills should contact the TDEC regarding environmental compliance.

#### **Maintenance**

- ❖ Inspect storage areas before and after rainfall events, and at least weekly during other times.
- ❖ Inspect to ensure that designated storage areas are kept clean and well organized.
- ❖ Repair and/or replace perimeter controls, containment structures, and covers as needed to keep them properly functioning.
- ❖ Conduct routine weekly inspections.
- ❖ Weekly inspection should be considered and include:
  - Check for external corrosion and structural failure,
  - Check for spills and overfills due to operator error,
  - Check for failure of piping system (pipes, pumps, flanges, coupling, hoses, and valves),
  - Check for leaks or spills during pumping of liquids or gases from truck or rail car to a storage facility or vice versa,
  - Visually inspect new tank or container installation loose fittings, poor welding, and improper or poorly fitted gaskets, and
  - Inspect tank foundations, connections, coatings, and tank walls and piping system. Look for corrosion, leaks, cracks, scratches, and other physical damage that may weaken the tank or container system.

#### **Limitations**

- ❖ Space limitation may preclude indoor storage.
- ❖ Storage sheds must meet building & fire code requirements.
- ❖ Space and time limitations may preclude all transfers from being performed indoors or under cover.
- ❖ It may not be possible to conduct transfers only during dry weather.
- ❖ Costs may be prohibitive when covering a large loading/unloading area.

#### **Additional Information**

##### ***Container Management***

- ❖ To limit the possibility of stormwater pollution, containers used to store dangerous waste or other liquids should be kept inside the building unless this is impractical due to



site constraints. If the containers are placed outside, the following procedures should be employed:

- Dumpsters used to store items awaiting transfer to a landfill should be placed in a lean-to structure or otherwise covered. Dumpsters shall be kept in good condition without corrosion or leaky seams. All drain valves should be closed.
  - Garbage dumpsters shall be replaced if they are deteriorating to the point where leakage is occurring. It should be kept undercover to prevent the entry of stormwater. Employees should be made aware of the importance of keeping the dumpsters covered and free from leaks.
  - A fillet should be placed on both sides of the curb to facilitate moving the dumpster.
  - Waste container drums should be kept in an area such as a service bay. If drums are kept outside, they must be stored in a lean-to type structure, shed or walk-in container to keep rainfall from reaching the drums.
- ❖ Storage of reactive, ignitable, or flammable liquids must comply with the fire codes of your area. Practices listed below should be employed to enhance the fire code requirements.
- Containers should be placed in a designated area.
  - Designated areas should be paved, free of cracks and gaps, and impervious in order to contain leaks and spills.
  - Liquid waste should be surrounded by a curb or dike to provide the volume to contain 10 percent of the volume of all of the containers or 110 percent of the volume of the largest container, whichever is greater.
  - The area inside the curb should slope to a drain.
  - For used oil or dangerous waste, a dead-end sump should be installed in the drain.
  - All other liquids should be drained to the sanitary sewer if available. The drain must have a positive control such as a lock, valve, or plug to prevent release of contaminated liquids.
  - The designated storage area should be covered.
  - Containers used for liquid removal by employees must be placed in a containment area.
  - A drip pan should be used at all times.
  - Drums stored in an area where unauthorized persons may gain access must be secured to prevent accidental spillage, pilferage, or any unauthorized use.
  - Employees trained in emergency spill cleanup procedures should be present when dangerous waste, liquid chemicals, or other wastes are loaded or unloaded.

#### ***Operator Training/Safeguards***

- ❖ Well-trained employees can reduce human errors that lead to accidental releases or spills. Employees should be familiar with the Spill Prevention Control and Countermeasure (SPCC) Plan. The employee should have the tools and knowledge to immediately begin cleaning up a spill if one should occur. Operator errors can be prevented by using engineering safeguards and thus reducing accidental releases of pollutant.



- ❖ Tank systems should be inspected and tank integrity tested regularly. Problem areas can often be detected by visually inspecting the tanks frequently. Problems or potential problems should be corrected as soon as possible. Registered and specifically trained professional engineers can identify and correct potential problems such as loose fittings, poor welding, and improper or poorly fitted gaskets for newly installed tank systems. The tank foundations, connections, coatings, and tank walls and piping systems also should be inspected. Inspection for corrosion, leaks, cracks, scratches in protective coatings, or other physical damage that may weaken the tank system should be a part of regular integrity testing.

#### ***Secondary Containment***

- ❖ Tanks should be bermed or surrounded by a secondary containment system. Leaks can be detected more easily and spills can be contained when secondary containment systems are installed. Berms, dikes, liners, vaults, and double-wall tanks are examples of secondary containment systems.
- ❖ One of the best protective measures against contamination of stormwater is diking. Containment dikes are berms or retaining walls that are designed to hold spills. Diking is an effective pollution prevention measure for above ground storage tanks and railcar or tank truck loading and unloading areas. The dike surrounds the area of concern and holds the spill, keeping spill materials separated from the stormwater side of the dike area. Diking can be used in any industrial facility, but it is most commonly used for controlling large spills or releases from liquid storage areas and liquid transfer areas.
- ❖ For single-wall tanks, containment dikes should be large enough to hold the contents of the storage tank for the facility plus rain water. For trucks, diked areas should be capable of holding an amount equal to the volume of the tank truck compartment. Diked construction material should be strong enough to safely hold spilled materials. Dike materials can consist of earth, concrete, synthetic materials, metal, or other impervious materials. Strong acids or bases may react with metal containers, concrete, and some plastics. Where strong acids or bases are stored, alternative dike materials should be considered. More active organic chemicals may need certain special liners for dikes. Dikes may also be designed with impermeable materials to increase containment capabilities. Dikes should be inspected during or after significant storms or spills to check for washouts or overflows. Regular checks of containment dikes to insure the dikes are capable of holding spills should be conducted. Inability of a structure to retain stormwater, dike erosion, soggy areas or changes in vegetation indicates problems with dike structures. Damaged areas should be patched and stabilized immediately. Earthen dikes may require special maintenance of vegetation such as mulching and irrigation.
- ❖ Curbing is a barrier that surrounds an area of concern. Curbing is similar to containment diking in the way that it prevents spills and leaks from being released into the environment. The curbing is usually small scaled and cannot contain large spills like diking. Curbing is common at many facilities in small areas where handling and transferring liquid materials occur. Curbing can redirect contaminated stormwater away from the storage area. It is useful in areas where liquid materials are transferred



from one container to another. Asphalt is a common material used for curbing; however, curbing materials include earth, concrete, synthetic materials, metal, or other impenetrable materials. Spilled materials should be removed immediately from curbed areas to allow space for future spills. Curbs should have manually-controlled pump systems rather than common drainage systems for collection of spilled materials. The curbed area should be inspected regularly to clear clogging debris. Maintenance should also be conducted frequently to prevent overflow of any spilled materials as curbed areas are designed only for smaller spills. Curbing has the following advantages:

- Excellent run-on control,
- Inexpensive,
- Ease of installment,
- Provides option to recycle materials spilled in curbed areas, and
- Common industry practice.

## References

CDM et.al. for the California SWQTF, 1993. *California Storm Water Best Management Practice Handbooks, Industrial Handbook*.

City of Seattle, 1989. *Water Quality Best Management Practices Manual*.

Santa Clara Valley Nonpoint Source Pollution Control Program, 1992. *Best Management Practices for Industrial Storm Water Pollution Control*.

USEPA, 1992. *Storm Water Management for Industrial Activities: Developing Pollution Prevention Plans, and Best Management Practices*, EPA 832-R-92-006.



## Outdoor Process Equipment Operations & Maintenance

ICP – 07

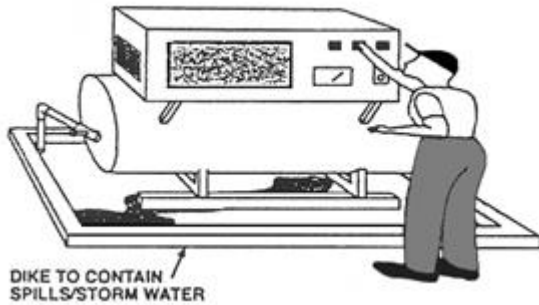

Hamilton County



Water Quality Program

**Description** Prevent or reduce the discharge of pollutants to stormwater from outdoor process equipment operations and maintenance by reducing the amount of waste created, enclosing or covering all or some of the equipment, installing secondary containment, and training employees. This management practice is likely to create significant reductions in sediment, heavy metals, toxic materials, and oil and grease.

**Approach** Outside process equipment operations can contaminate stormwater runoff. Activities, such as rock grinding or crushing, painting or coating, grinding or sanding, degreasing or parts cleaning, landfills, waste piles, wastewater and solid waste treatment and disposal, and land application are process operations that use hazardous materials and that can lead to contamination of stormwater runoff. Pollutants from the wastewater and solid waste treatment and disposal areas result from waste pumping, additions of treatment chemicals, mixing, aeration, clarification, and solids dewatering.

- ❖ Alter the activity to prevent exposure of pollutants to stormwater.
- ❖ Move activity indoors.
- ❖ Cover the area with a permanent roof.
- ❖ Minimize contact of stormwater with outside manufacturing operations through berming and drainage routing (run-on prevention).
- ❖ Connect process equipment area to public sewer or facility wastewater treatment system.
- ❖ Clean regularly the stormwater system.
- ❖ Use catch basin filtration inserts as a means to capture particulate pollutants.
- ❖ Some municipalities require that secondary containment areas (regardless of size) be connected to the sanitary sewer, prohibiting any hard connections to the storm drain.
- ❖ The preferred (and possibly the most economical) action to reduce stormwater pollution is to alter the nature of activity such that pollutants are not exposed to stormwater. This may mean performing the activity during dry periods only or substituting benign materials for more toxic ones.
- ❖ Actions other than altering the activity include enclosing the activity in a building and connecting the floor drains to the sanitary sewer.
- ❖ The area used by the activity may be so great as to make enclosure prohibitively expensive. Building cost can be reduced by not covering the sides, and thus eliminating the need for ventilating and lighting systems.
- ❖ When certain parts of the activity are the worst source of pollutants, those parts can be segregated and enclosed or covered.
- ❖ Curbs can be placed around the immediate boundaries of the process equipment. The





storm drains from these interior areas can be connected to the facility's process wastewater system.

- ❖ Reducing the amount of waste that is created and consequently the amount that must be stored or treated is another way to reduce the potential for stormwater contamination from outside manufacturing activities.

#### ***Treatment***

If stormwater becomes polluted, used in a mechanical process, or as a cooling or cleaning solution, it should be captured and treated. If you do not have your own process wastewater treatment system, consider discharging to the public sewer system. Use of the public sewer might be allowed under the following conditions:

- ❖ It may be possible under unusual circumstances to connect a much larger area to the public sewer, as long as the rate of stormwater discharges do not exceed the capacity of the wastewater treatment plant. The stormwater could be stored during the storm and then transferred to the public sewer when the normal flow is low, such as at night.
- ❖ The majority of the pollutants in stormwater are discharged over time by the small, high frequency storms. Less polluted runoff from the infrequent large storms can be bypassed to the storm drain. To implement this BMP, a hydraulic evaluation of the downstream sewer system should occur in consultation with the local sewer authority.

**Maintenance** Routine preventive maintenance, including checking process equipment for leaks.

- Limitations**
- ❖ Providing cover may be expensive.
  - ❖ Space limitations may preclude enclosing some equipment
  - ❖ Storage sheds often must meet building and fire code requirements.

**Additional Information** Possible stormwater contaminants from operation and maintenance described above include heavy metals, toxic materials, and oil and grease. Waste spilled, leaked, or lost from outdoor process equipment operations may build up in soils or on other surfaces and be carried away by stormwater runoff. There is also a potential for liquid waste from lagoons or surface impoundments, associated with outdoor equipment operations, to overflow to surface waters or soak the soil, which eventually can be picked up by stormwater runoff.

Industries that generate large volumes of process wastewater typically have their own treatment system that discharges directly to the nearest receiving water. These industries have the discretion to use their wastewater treatment system to treat stormwater within the constraints of their permit requirements for process treatment. It may also be possible for the industry to discharge the stormwater directly to its effluent outfall without treatment as long as the total loading or concentration of the discharged process water and stormwater does not exceed the loading or concentration had a stormwater treatment device been used. This could be achieved by reducing the loading from the process wastewater treatment system. Check with the local sewer authority, as this option would be subject to permit constraints and potentially regular monitoring.

**References** CDM et al. April 1997. *Caltrans Storm Water Quality Handbooks, Construction Contractor's Guide and Specifications*.

City of Seattle, 1989. *Water Quality Best Management Practices Manual*.



Santa Clara Valley Nonpoint Source Pollution Control Program, 1992. *Best Management Practices for Industrial Storm Water Pollution Control*.

California Department of Toxic Substances Control, Sacramento, CA, 1991. *Publications That Can Work For You!* (A list and order form for waste minimization publications from the State).

USEPA, 1992. *Storm Water Management for Industrial Activities: Developing Pollution Prevention Plans, and Best Management Practices*, EPA 832-R-92-006.



## Waste Handling & Disposal

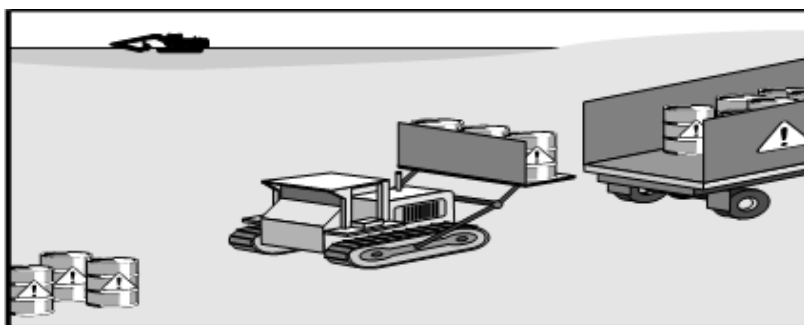

## ICP – 08

### Hamilton County



### Water Quality Program

#### Description

Prevent or reduce the discharge of pollutants to stormwater from waste handling and disposal by tracking waste generation, storage, and disposal; reducing waste generation and disposal through source reduction, re-use, and recycling; and preventing run-on and runoff from waste management areas. This management practice is likely to create a significant reduction in heavy metals, toxic materials, floatable materials, oxygen demanding substances, oil and grease, bacteria and viruses.

#### Approach

Many of the approaches presented in BMPs CP-06: Spill Prevention and Control, CP-07: Solid Waste Management, CP-08: Hazardous Waste Management, ICP-05: Outdoor Loading/Unloading and Storage of Materials, and ICP-06: Outdoor Container Storage of Liquids is applicable to ICP-08: Waste Handling and Disposal.

- ❖ Maintain usage inventory to limit waste generation.
- ❖ SARA Title III, Section 313 requires reporting for over 300 listed chemicals and chemical compounds. This requirement should be used to track these chemicals although this is not as accurate a means of tracking as other approaches.
- ❖ Track waste generated:
  - Characterize waste stream.
  - Evaluate the process generating the waste.
  - Prioritize waste streams using: manifests, biennial reports, permits, environmental audits, SARA Title III reports, emission reports, NPDES monitoring reports.
  - Inventory reports.
  - Data on chemical spills.
  - Emissions.
  - Shelf life expiration.
- ❖ Use raw material and production data and review: composition sheets, materials safety data sheets (MSDS), batch sheets, product or raw material inventory records, production schedule, operator data log.
- ❖ To eliminate or substitute some raw materials to reduce waste generation.
- ❖ Use design data and review: process flow diagram, materials and applications diagram, piping and instructions, equipment list, plot plan.
- ❖ Modify the process or equipment to reduce waste generation or contain waste more safely there by limiting potential stormwater impacts.
- ❖ Production planning and sequencing to limit exposure of hazardous or other waste to rainfall during transfer or disposal.
- ❖ Recycle materials whenever possible.



- ❖ Maintain list of and the amounts of materials disposed. This is also required for all SARA Title II listed materials.
- ❖ Segregate and separate waste to facilitate recycling.
- ❖ Check industrial waste management areas for spills and leaks.
- ❖ Cover, enclose, or berm industrial wastewater management areas whenever possible to prevent contact with run-on or runoff.
- ❖ Equip waste transport vehicles with spill containment equipment.
- ❖ Minimize spills and fugitive losses such as dust or mist from loading systems.
- ❖ Ensure that sediments or wastes are prevented from being tracked off-site.
- ❖ Stencil storm drains on the facility's property with prohibitive message regarding waste disposal limitations. Messages may include notice that the drain is a "separate storm sewer system" or that it goes to the facility pre-treatment plant.
- ❖ For a quick reference on disposal alternatives for specific wastes, see Table ICP-12-1 presented in the Employee/Subcontractor Training BMP fact sheet.

### ***Education***

- ❖ Thoroughly train employees in proper handling and disposal of wastes at the site/facility. This should include periodic review of the material safety data sheets.
- ❖ Educate employees and subcontractors on hazardous waste storage and disposal procedures.
- ❖ Educate employees and subcontractors of potential dangers to humans and the environment from hazardous wastes.
- ❖ Instruct employees and subcontractors on safety procedures for common construction site hazardous wastes.
- ❖ Instruct employees and subcontractors in identification of hazardous and solid waste.
- ❖ Hold regular meetings to discuss and reinforce disposal procedures (incorporate into regular safety meetings).
- ❖ Designate a foreman or supervisor to oversee and enforce proper solid waste management procedures and practices.
- ❖ Make sure that hazardous waste is collected, removed, and disposed of only at authorized disposal areas.

### ***Storage Procedures***

- ❖ Ensure that adequate hazardous waste storage volume is available.
- ❖ Ensure that hazardous waste collection containers are conveniently located.
- ❖ Designate hazardous waste storage areas on site, away from storm drains or watercourses.
- ❖ Use containment berms in fueling and maintenance areas and where the potential for spills is high.
- ❖ Store hazardous materials and wastes in covered containers and protected from vandalism.
- ❖ Keep liquid or semi-liquid hazardous waste in appropriate containers (closed drums or similar) and under cover.
- ❖ Clearly mark on all hazardous waste containers which materials are acceptable for the container.
- ❖ Place hazardous waste containers in secondary containment.
- ❖ Do not allow potentially hazardous waste materials to accumulate on the ground.



- ❖ Do not mix wastes, as this can cause chemical reactions, make recycling impossible, and complicate disposal.

***Disposal Procedures***

- ❖ Regularly schedule hazardous waste removal to minimize on-site storage.
- ❖ Arrange for regular waste collection before containers overflow.
- ❖ Use only reputable, licensed hazardous waste haulers.
- ❖ Make sure that toxic liquid wastes (used oils, solvents, and paints) and chemicals (acids, pesticides, additives, curing compounds) are not disposed of in dumpsters designated for construction debris.
- ❖ Recycle any useful material such as used oil or water-based paint.

**Maintenance**

None except for maintaining equipment for material tracking program and permanent oil/water separators. Foreman and/or construction supervisor should monitor on-site hazardous waste storage and disposal procedure.

**Limitations**

- ❖ Hazardous waste that cannot be re-used or recycled must be disposed of by a licensed hazardous waste hauler.
- ❖ Major contamination, large spills, and other serious hazardous waste incidents require immediate response from specialists.
- ❖ Demolition activities and potential pre-existing materials, such as asbestos, are not addressed by this program.

**References**

CDM et.al. for the California SWQTF. 1993. *California Storm Water Best Management Practice Handbooks, Industrial Handbook*.

California Department of Toxic Substances Control, Sacramento, CA. 1991. *Publications That Can Work For You!* (A list and order form for waste minimization publications from the State).

USEPA, 1992. *Storm Water Management for Industrial Activities: Developing Pollution Prevention Plans, and Best Management Practices*, EPA 832-R-92-006.

USEPA. 1992. *Distribution List - Pollution Prevention Information Clearinghouse*.



## Contaminated or Erodible Surface Areas

ICP – 09

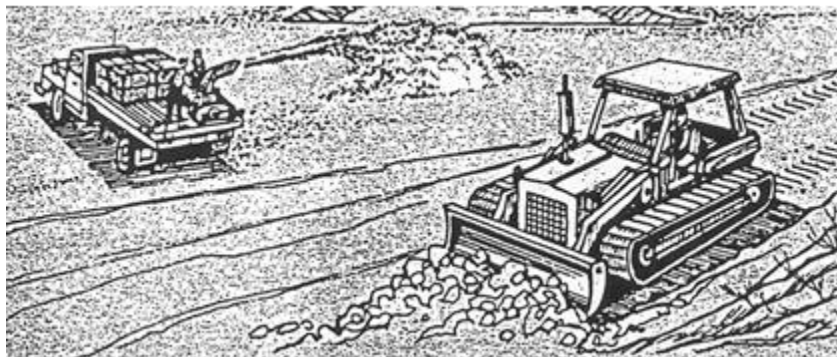

Hamilton County



Water Quality Program

### Description

Prevent or reduce the discharge of pollutants to stormwater from contaminated or erodible surface areas by leaving as much vegetation on-site as possible, minimizing soil exposure time, stabilizing exposed soils, and preventing stormwater run-on into or controlling/treating run-off from contaminated areas. This management practice is likely to create significant reductions in sediment, nutrients, heavy metals, toxic materials, floatable materials, oxygen demanding substances, and oil and grease.

### Approach

- ❖ The most effective way to control erosion is to preserve existing vegetation. Preservation of natural vegetation provides a natural buffer zone and an opportunity for infiltration of stormwater and capture of pollutants in the soil matrix. By preserving stabilized areas, it minimizes erosion potential, protects water quality, and provides aesthetic benefits. This practice is used as a permanent control measure.
- ❖ Contaminated or erodible surface areas can be controlled by:
  - Removal of contaminated soils,
  - Preservation of natural vegetation,
  - Re-vegetation,
  - Chemical stabilization,
  - Geosynthetics, or
  - Run-on diversion and/or Runoff control/treatment with sediment cups/basins or dry/wet detention ponds.
- ❖ Vegetation preservation on-site should be planned before disturbing the site. Preservation requires good site management to minimize the impact of construction when construction is underway.
- ❖ Proper maintenance is important to ensure healthy vegetation that can control erosion. Maintenance should be performed regularly especially during construction phases.
- ❖ Different species, soil types, and climatic conditions will require different maintenance activities such as mulching, fertilizing, liming, irrigation, pruning and weed and pest control.

Advantages of preservation of natural vegetation are:

- ❖ Vegetated areas can handle higher quantities of stormwater runoff than newly seeded areas.
- ❖ Removal of contaminated soils is a last resort, unless regulated by TDEC, and quite expensive. The level and extent of the contamination must be determined. This



determination and removal must comply with State and Federal regulations, permits must be acquired, and fees paid.

For a quick reference on disposal alternatives for specific wastes, see Table ICP-12-1 presented in the Employee/Subcontractor Training BMP fact sheet.

**Maintenance**

Maintenance should be minimal, except possibly if irrigation of vegetation is necessary.

**Limitations**

- ❖ Except for preservation of natural vegetation, each of the above solutions can be quite expensive depending upon the size of the area.
- ❖ Requires some planning to preserve and maintain the existing vegetation.
- ❖ May not be cost-effective with high land or contaminated soil disposal costs.
- ❖ Poor soils may limit the success of re-vegetated areas.
- ❖ Disadvantages of chemical stabilization include:
  - Creation of impervious surfaces.
  - May reduce erosion but cause different harmful effects on stormwater quality.
  - Is usually more expensive than vegetative cover.

**Suitable Applications**

This BMP addresses soils which are not so contaminated as to exceed criteria requiring a permit from TDEC, but the soil is eroding or carrying pollutants off in the stormwater. Much of the information presented in CP-09: Contaminated Soil Management can also be applied to this practice.

Of interest here are areas within the industrial site that are bare of vegetation and therefore subject to erosion. They may or may not be contaminated from past or current activities. Activity may or may not be occurring in the area of interest.

Contaminated or erodible surfaces can result from the human activities such as vegetation removal, compacting or disturbing soil, and changing natural drainage patterns. Industries must identify the areas of contaminated or erodible surfaces. The areas may include:

- ❖ Heavy activity where plants cannot grow.
- ❖ Soil stockpiles.
- ❖ Steep slopes.
- ❖ Construction areas.
- ❖ Demolition areas.
- ❖ Any area where soil is disturbed.



**Additional Information**

- ❖ Natural vegetation increases the filtering capacity because surface growth and root systems are usually dense in preserved natural vegetation.
- ❖ It provides areas for infiltration and “rougher” flow paths, thus reducing the quantity and velocity of stormwater runoff.
- ❖ It allows areas where wildlife can remain undisturbed or stressed.
- ❖ Tall and dense vegetation can provide noise buffers and screens for on-site operations/processes.
- ❖ It usually requires less maintenance than planting new vegetation.
- ❖ Geosynthetics include those materials that are designed as an impermeable barrier to contain or control large amounts of liquid or solid matter. Some geosynthetics have been developed primarily for use in landfills and surface impoundments, and the technology is well established. There are two general types of geosynthetics: geomembranes (impermeable) and geotextiles (permeable).
  - Geomembranes are composed of one of three types of impermeable materials: elastomers (rubbers), thermoplastics (plastics), or a combination of these two types of materials.
  - The advantages of these materials include:
    1. the variety of compounds available,
    2. sheeting is produced in a factory environment,
    3. polymeric membranes are flexible, and
    4. simple installation.
  - The disadvantages include:
    1. chemical resistance must be determined for each application,
    2. seaming systems may be a weak link in the system, and
    3. many materials are subject to attack from biotic, mechanical, or environmental sources.
  - Geotextiles are uncoated synthetic textile products that are not watertight. They are composed of a variety of materials, most commonly polypropylene and polyester. Geotextiles serve five basic functions:
    1. filtration
    2. drainage
    3. separation
    4. reinforcement, and
    5. armoring.

**References**

CDM et.al. April 1997. *Caltrans Storm Water Quality Handbooks, Construction Contractor's Guide and Specifications.*

USEPA. 1985. *Covers for Uncontrolled Hazardous Waste Sites*, EPA/540/2-85/002, PB87-119483.





## Building and Grounds Construction & Maintenance

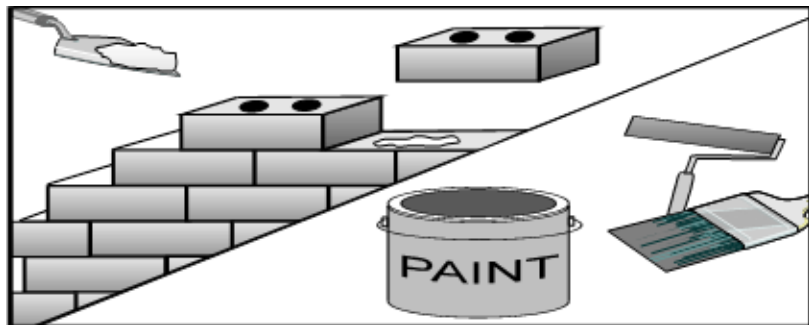

ICP – 10

Hamilton County



Water Quality Program

### Description

Prevent or reduce the discharge of pollutants to stormwater from buildings and grounds construction and maintenance by using soil erosion controls, enclosing or covering building material storage areas, using good housekeeping practices, using safer alternative products, training employees, washing and cleaning up with as little water as possible, preventing and cleaning up spills immediately, keeping debris from entering the storm drains, and maintaining the stormwater collection system. This management practice is likely to create a significant reduction in sediment, nutrients, heavy metals, toxic materials, floatable materials, oxygen demanding substances, and oil and grease.

### Approach

Modifications are common occurrence particularly at large industrial sites. The activity may vary from landscaping maintenance to minor and normal building repair to major remodeling, or the installation of new facilities on currently open space. These activities can generate pollutants that can reach stormwater if proper care is not taken. The sources of these contaminants may be pesticides, herbicides, fertilizers, solvents, paints, and varnish removers, finishing residues, spent thinners, soap cleaners, kerosene, asphalt and concrete materials, adhesive residues, and old asbestos installation.

- ❖ Leaving or planting native vegetation to reduce water, fertilizer, and pesticide needs.
- ❖ Careful use of pesticides and fertilizers in landscaping.
- ❖ Integrated pest management where appropriate.
- ❖ Sweeping of paved surfaces.
- ❖ Cleaning of the stormwater system at appropriate intervals.
- ❖ Proper disposal of wash water, sweepings, and sediments.
- ❖ Remove debris in a timely fashion to keep the work site clean and orderly.
- ❖ Collect and properly dispose of roofing debris prior to rainfall and upon completion of work to prevent entry of debris and materials into gutter downspouts.
- ❖ Inform employees and subcontractors of acceptable housekeeping, disposal and other stormwater management practices and include appropriate provisions in subcontracts to make certain proper housekeeping disposal and other stormwater management practices are implemented.
- ❖ Do not remove original product labels as they contain important safety and disposal information.
- ❖ Make Material Safety Data Sheets (MSDSs) available to all employees and review in



- periodic safety training.
- ❖ Use soil erosion control techniques if bare ground is temporarily exposed. See Section 2, Contractor Management Practices (CPs) and Section 3, Temporary Construction Site Management Practices (TCPs) within this manual.
- ❖ Use permanent soil erosion control techniques if the remodeling clears buildings from an area that is not to be replaced. See the Permanent Erosion and Sediment Control Management Practices (PESC) section of this manual.
- ❖ Enclose painting operations, consistent with local air quality regulations and OSHA.
- ❖ Properly store materials that are normally used in repair and remodeling such as paints and solvents.
- ❖ Properly store and dispose waste materials generated from the activity. ICP-8: Waste Handling and Disposal BMP fact sheet.
- ❖ Mix paint indoors, or in a containment area.
- ❖ Use the entire product before disposing of the container.
- ❖ For water-based paints, paint out brushes to the extent practical, and rinse to a drain leading to a sanitary sewer where permitted, or into a concrete washout pit or temporary sediment trap.
- ❖ For oil-based paints, paint out brushes to the extent practical, and filter and reuse thinners and solvents.
- ❖ Never clean paintbrushes or rinse paint containers into a street, gutter, storm drain or watercourse.
- ❖ For a quick reference on disposal alternatives for specific wastes, see Table ICP-12-1 presented in the Employee/Subcontractor Training BMP fact sheet. Dispose of any paint, thinners, residue, and sludge that cannot be recycled as hazardous waste.
- ❖ Latex paint and paint cans, used brushes, rags, absorbent materials, and drop cloths, when thoroughly dry and are no longer hazardous, may be disposed of with other construction debris.
- ❖ Recycle residual paints, solvents, lumber, and other materials to the maximum extent practical. Buy recycled products to the maximum extent practical.

#### Requirements

- ❖ Costs (Capital, I&M)
  - Cost will vary depending on the type and size of facility.
  - Overall costs should be low in comparison to structural BMPs.

#### Maintenance

- ❖ The BMPs themselves relate to training, maintenance and construction activities that do not require maintenance as they do not involve structures. However, regular inspection and refresher training is warranted.
- ❖ Spot check employees and subcontractors at least monthly throughout the job to ensure appropriate practices are being employed.

#### Limitations

- ❖ Alternative pest/weed controls may not be available, suitable, or effective in every case.
- ❖ Safer alternative building and construction products may not be available or suitable in every instance.
- ❖ This BMP is for minor construction only.
- ❖ Hazardous waste that cannot be re-used or recycled must be disposed of by a licensed hazardous waste hauler.



- ❖ Be certain that actions to help stormwater quality are consistent with TDEC and Fed-OSHA and air quality regulations.

**Additional  
Information**

Pesticide/Fertilizer Management

Landscape maintenance involves the use of pesticides and fertilizers. Proper use of these materials will reduce the risk of loss to stormwater. In particular, do not apply these materials during rain as they may be carried from the site by the runoff. When irrigating the landscaped areas, avoid over-watering not only to conserve water but to avoid the discharge of water, which may have become contaminated with excess nutrients and pesticides.

It is important to properly store pesticides and application equipment, and to dispose the used containers in a responsible manner, consistent with TDEC regulations. Personnel who use pesticides should be trained in their use.

Written procedures for the use of pesticides and fertilizers relevant to your facility would help maintenance staff understand the “do’s” and don’ts”. If you have large vegetated areas, consider the use of integrated pest management (IPM) techniques to reduce the use of pesticides.

***Good Housekeeping***

Proper care involves a variety of mostly common sense, housekeeping actions such as:

- ❖ Keep the work site clean and orderly. Removing debris in a timely fashion. Sweep the area.
- ❖ Cover materials of particular concern that must be left outside.
- ❖ Educate employees who are doing the work about the importance of keeping pollutants out of the stormwater system including review of the Spill Prevention, Control and Countermeasures (SPCC) Plan.
- ❖ Inform on-site contractors of company policy on these matters and include appropriate provisions in their contract to make certain proper housekeeping and disposal practices are implemented.
- ❖ Make sure that nearby storm drains are well marked to minimize the chance of inadvertent disposal of residual paints and other liquids.
- ❖ Advise concrete truck drivers to not wash their truck over the storm drain. Have a designated area that does not drain to the storm drain. See CP-10: Concrete Waste Management.
- ❖ Clean the storm drain system in the immediate vicinity after the construction activity is completed.

Proper education of off-site contractors is often overlooked. The conscientious efforts of well trained employees can be lost by unknowing off-site contractors, so make sure they are well informed about what they are expected to do. See ICP-12: Employee/ Subcontractor Training.



Painting operations should be properly enclosed or covered to avoid drift. Use temporary scaffolding to hang drop cloths or draperies to prevent drift. Application equipment that minimizes overspray also helps. Air pollution regulations may, specify painting procedures which if properly carried out are usually sufficient to protect water quality. If painting requires scraping or sand blasting of the existing surface, use a ground cloth to collect the chips. Dispose the residue properly. If the paint contains lead or tributyl tin, it is considered a hazardous waste.

Mix paint indoors before using so that any spill will not be exposed to rain. Do so even during dry weather because cleanup of a spill will never be 100% effective. Dried paint will erode from a surface and be washed away by storms. If using water based paints, clean the application equipment in a sink that is connected to the sanitary sewer. Properly store leftover paints if they are to be kept for the next job, or dispose properly.

When using sealants on wood, pavement, roofs, etc. quickly clean up spills. Remove excess liquid with absorbent material or rags. If when repairing roofs, small particles have accumulated in the gutter, either sweep out the gutter or wash the gutter and trap the particles at the outlet of the downspout. A sock or geofabric placed over the outlet may effectively trap the materials. If the downspout is tight lined, place a temporary plug at the first convenient point in the storm drain and pump out the water with a vacuum truck, and clean the catch basin sump where you placed the plug.

#### ***Parking/Storm Sewer Maintenance***

A parking area that drains to the same stormwater system as the industrial activity that is to be permitted must also be evaluated for suitable BMPs. Stormwater from parking lots may contain undesirable concentrations of oil, grease, suspended particulates, and metals such as copper, lead, cadmium, and zinc, as well as the petroleum byproducts of engine combustion. Deposition of air particulates, generated by the facility or by adjacent industries, may contribute significant amounts of pollutants.

The two most appropriate maintenance BMPs are periodic sweeping and cleaning catch basins if they are part of the stormwater system. A vacuum sweeper is the best method of sweeping, rather than mechanical brush sweeping which is not as effective at removing the fine particulates.

Catch basins in parking lots generally need to be cleaned every 6 to 12 months, or whenever the sump is half full. A sump that is more than half full is not effective at removing additional particulate pollutants from the stormwater. If the storm drain lines have a low gradient, less than about 0.5 feet in elevation drop per 100 feet of line, it is likely that material is settling in the lines during the small, frequent storms. If you have not cleaned the storm drain system for some time, check the lines as well. If they are not cleaned, the catch basins will likely be filled during the next significant storm by material that is washed from the lines. Also, install skimmers, “turn-down” elbows or similar devices on the outlets of the catch basins; they serve to retain floatables, oil and grease.

Clearly mark the storm drain inlets, either with a color code (to distinguish from



pretreatment-process water inlets if you have them) or with the painted stencil. This will minimize inadvertent dumping of liquid wastes.

Sweepings and sediments from these maintenance activities are generally low in metals and other pollutants and therefore can be disposed on-site or to a construction debris landfill. Test the material if there is a reasonable doubt whether metals or other pollutants are present. If concentrations of contaminants are high, it indicates that other BMPs may be needed to eliminate or reduce emissions from the source. If a vactor truck is used to clean the storm drainage system, dirty water will be generated. This water should not be discharged to the storm drainage system as it is silt laden and contains much of the pollutants that were removed by the catch basins. The water should be disposed to the process wastewater system, if available or to the public sewer if permission is granted by the local sewer authority. Alternatively, the water can be placed somewhere on the site where it can evaporate such as a sediment trap or basin.

If some employees have cars that are leaking abnormal amounts of engine fluids, encourage them to have the problem corrected.

#### ***Older Buildings and Sewers***

If a building is to be placed over an open area with a storm drainage system, make sure that storm inlets within the building are covered or removed, or the storm line is connected to the sanitary sewer. If because of the remodeling a new drainage system is to be installed or the existing system is to be modified, consider installing catch basins as they serve as effective “in-line” treatment devices. Include in the catch basin a “turn-down” elbow or similar device to trap floatables.

#### **References**

CDM et. al. April 1997. *Caltrans Storm Water Quality Handbooks, Construction Contractor’s Guide and Specifications.*

Santa Clara Valley Nonpoint Source Pollution Control Program. 1992. *Best Management Practices for Industrial Storm Water Pollution Control.*



## Over-Water Activities

## ICP – 11

### Hamilton County



### Water Quality Program

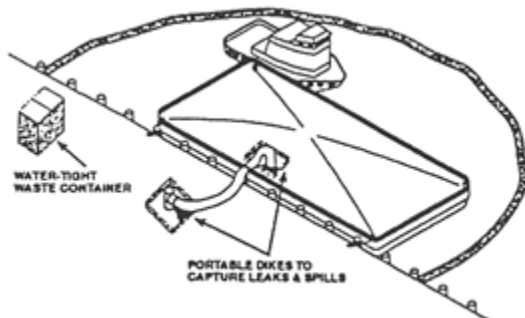

#### Description

Prevent or reduce the discharge of pollutants to stormwater and receiving waters from over-water activities by minimizing over-water maintenance, keeping wastes out of the water, cleaning up spills and wastes immediately, and educating tenants and employees. This management practice is likely to create a significant reduction in heavy metals, toxic materials, floatable materials, oil and grease, oxygen demanding substances, and bacteria and viruses.

#### Suitable Applications

Over-water activities occur at boat and ship repair yards, marinas, and yacht clubs, although the latter are not required to obtain a permit. Activities of concern include chipping and painting of hulls, on board maintenance of engines, and the disposal of domestic wastewater and ballast water. With few exceptions, BMPs to protect water quality are common sense, low cost changes to normal day-to-day procedures.

#### Approach

- ❖ Properly dispose of domestic wastewater and ballast water.
- ❖ Limit over-water hull surface maintenance to sanding and minor painting.
- ❖ Use phosphate-free and biodegradable detergents for hull washing.
- ❖ Use secondary containment on paint cans.
- ❖ Have available spill containment and cleanup materials.
- ❖ Use ground cloths when painting boats on land.
- ❖ Use tarps, plastic sheeting, etc. to contain spray paint and blasting sand.
- ❖ Properly dispose of surface chips, used blasting sand, residual paints, and other materials. Use temporary storage containment that is not exposed to rain.
- ❖ Immediately clean up spills on docks or boats.
- ❖ Sweep drydocks before flooding.
- ❖ Clean catch basins and the storm drains at regular intervals.
- ❖ Post signs to indicate proper use and disposal of residual paints, rags, used oil, and other engine fluids.
- ❖ Educate tenants and employees on spill prevention and cleanup including review of the Spill Prevention, Control and Countermeasures (SPCC) Plan.
- ❖ Include appropriate language in tenant contracts indicating their responsibilities to guard against spills, properly dispose solid, liquid and hazardous waste, and limit practices that may pollute stormwater.
- ❖ Marinas should provide wastewater disposal facilities.



***Over-Water Activity Minimization***

Work on boats in the water should be kept to a minimum. Major hull resurfacing should occur on land. Surface preparation over water should be limited to sanding. Painting should be limited to spot work. In marinas, tenant maintenance over water should be such as to not require opening more than pint size paint can. Paint mixing should not occur on the dock.

***Good Housekeeping***

When conducting on board maintenance, used antifreeze should be stored in a separate, labeled drum and recycled. Fuel tank vents should have valves to prevent fuel overflows or spills. Boats with inboard engines should have oil absorption pads in bilge areas and should be changed when no longer useful or at least once a year.

Marina owners should provide temporary storage stations for used engine fluids, paint cans, and other maintenance materials. Signs should be posted at the head of each dock indicating maintenance rules. Marina owners should install a wastewater disposal system, either dockside lines or a pump out station.

When painting on shore, place paint cans in a tray or comparable device that collects spills and drips. Use spray guns that minimize overspray; also enclose the area with plastic tarps. Identify a designated area for washing boats. Vacuum sweep work areas frequently.

Large boat repair yards can implement the above BMPs. There are several additional measures. With regard to dry dock operations: sweep the accessible areas of the dry dock before flooding; and pick up other debris that appears after the ship is floated. Remove floatable debris such as wood. Shipboard cooling and process water discharges should be directed to minimize contact with spent abrasives, paints, and other debris. Look for and repair leaking valves, pipes, hoses, or soil shutes carrying either water or wastewater. Plastic sheeting or other suitable materials should be installed when sandblasting and spray painting.

Use drip pans or comparable devices when transferring oils, solvents, and paints. Regularly clean the shore side work areas of debris, sandblasting material, etc. Clean catch basins or other parts of the stormwater system that might accumulate these materials.

***Fish Wastes***

Fish wastes must also be managed properly. Recycling fish wastes back to the water is encouraged when disposal will not result in water quality or public nuisance problems, such as wastes washing up onshore or causing odors or bacteria problems. Fish wastes should not be recycled in any dead end lagoons or other poorly flushed areas. Marina owners should provide fish cleaning stations where waste recycling can occur without adversely affecting water quality.

**Maintenance** Keep ample supply of spill cleanup materials on hand and conspicuously marked.

**Limitations** Private tenants at marinas may resist restrictions on shipboard painting and maintenance.



Existing contracts with tenants may not allow the owner to require that tenants abide by new rules that benefit water quality. Even biodegradable cleaning agents have been found to be toxic to fish; therefore, they should only be disposed of through the sanitary sewer.

## References

*CDM et. al. April 1997. Caltrans Storm Water Quality Handbooks, Construction Contractor's Guide and Specification.*

*SFBRWQCB, 1992. General NPDES Permit for Discharges of Storm Water from Boat Repair Facilities.*

*USEPA, 1992. Proposed Guidance Specifying Management Measures for Sources of Nonpoint Pollution in Coastal Waters.*





## Employee Training

## ICP – 12



Hamilton County



Water Quality Program

### Description

Employee/subcontractor training, like maintenance or a piece of equipment, is not so much a best management practice as it is a method by which to implement BMPs. This fact sheet highlights the importance of training and of integrating the elements of employee/subcontractor training from the individual source controls into a comprehensive training program as part of a company's Storm Water Pollution Prevention Plan (SWPPP).

The specific employee/subcontractor training aspects of each of the source controls are highlighted in the individual fact sheets. The focus of this fact sheet is more general, and includes the overall objectives and approach for assuring employee/subcontractor training in stormwater pollution prevention. Accordingly, the organization of this fact sheet differs somewhat from the other fact sheets in this section.

### Objectives

Employee/subcontractor training should be based on five objectives:

1. Promote a clear identification and understanding of the problem, including facility/plant specific activities with the potential to drain to the stormwater and/or facility/plant pretreatment system;
2. Identify locations with higher potential for spills and leaks;
3. Identify solutions (BMPs);
4. Promote employee/subcontractor ownership of the problems and the solutions; and
5. Integrate employee/subcontractor feedback into training and BMP implementation.

### Approach

- ❖ Integrate training regarding stormwater quality management with existing training programs that may be required for your business by other regulations such as the 40-hour Hazardous Waste Operations and Emergency Response (HAZWOPER) standard (29 CFR 1910.120) and the Spill Prevention Control and Countermeasure (SPCC) Plan (40 CFR 112).
- ❖ Identify locations with higher potential for spills and leaks. This should include indoor and outdoor unloading/board and storage of materials, plant/facility processes, and disposal of solid, liquid, and hazardous wastes. Examples of leaks or spills at the site or facilities/plants of similar type should be discussed to review controllable and uncontrollable processes that lead to



- ❖ the spill or leak, actions that were taken by staff and actions that should have been taken by staff. Various similar case studies should be incorporated into regular periodic safety training.
- ❖ Businesses, particularly smaller ones that may not be regulated by Federal, State, or local regulations, may use the information in this Handbook to develop a training program to reduce their potential to pollute stormwater.
- ❖ Use the quick reference on disposal alternatives (Table ICP-12-1) to train employee/subcontractors in proper and consistent methods for disposal.
- ❖ Consider posting the quick reference table around the job site or in the on-site office trailer to reinforce training.
- ❖ Train employee/subcontractors in standard operating procedures and spill cleanup techniques described in the fact sheets. Employee/subcontractors trained in spill containment and cleanup should be present during the loading/unloading and handling of materials.
- ❖ Personnel who use pesticides, herbicides, fertilizers, etc. should be trained in their use.
- ❖ Proper education of off-site contractors is often overlooked. The conscientious efforts of well-trained employee/subcontractors can be lost by unknowing off-site contractors, so make sure they are well informed about what they are expected to do on-site.

## References

CDM et.al. for the California SWQTF, 1993. *California Storm Water Best Management Practice Handbooks, Construction Handbook.*

**TABLE ICP-12-1  
QUICK REFERENCE – DISPOSAL ALTERNATIVES**

All of the waste products on this chart are prohibited from discharge to the storm drain system. Use this matrix to decide which alternative disposal strategies to use. **ALTERNATIVES ARE LISTED IN PRIORITY ORDER.**

Key: HHW Household hazardous waste  
 POTW Publicly Owned Treatment Plant – WWTa or Moccasin Bend WTP  
 HCWQP Hamilton County Water Quality Program

“Dispose to sanitary sewer” means dispose into sink, toilet, or sanitary sewer clean-out connection.

“Dispose as trash” means dispose in dumpsters or trash containers for pickup and/or eventual disposal in landfill.

“Dispose as hazardous waste” for business/commercial means contract with a hazardous waste hauler to remove and dispose.

DISCHARGE/ACTIVITY	BUSINESS/COMMERCIAL		RESIDENTIAL
	Disposal Priorities	Approval	Disposal Priorities
<b>GENERAL CONSTRUCTION AND PAINTING: STREET AND UTILITY MAINTENANCE</b>			
Excess paint (oil based)	1. Recycle/reuse. 2. Dispose as hazardous waste.		1. Recycle/reuse. 2. Take to HHW drop-off.
Excess paint (water based)	1. Recycle/reuse 2. Dry residue in cans, dispose as trash. 3. If volume is too much to dry, dispose as hazardous waste.		1. Recycle/reuse. 2. Dry residue in cans, dispose as trash. 3. If volume is too much to dry, take to HHW drop-off.
Paint cleanup (oil based)	Wipe paint out of brushes, then: 1. Filter & reuse thinners, solvents. 2. Dispose as hazardous waste.		Wipe paint out of brushes, then: 1. Filter & reuse thinners, solvents. 2. Take to HHW drop-off.
Paint cleanup (water-based)	Wipe paint out of brushes, then Rinse to sanitary sewer.		Wipe paint out of brushes, then Rinse to sanitary sewer.
Empty paint cans (dry)	Remove lids, dispose as trash.		Remove lids, dispose as trash.
Paint stripping (with solvent)	Dispose as hazardous waste.		Take to HHW drop-off.
Building exterior cleaning (high-pressure water)	1. Prevent entry into storm drain and remove offsite. 2. Wash onto dirt area, spade in. 3. Collect (e.g. mop up) and discharge to sanitary sewer.	POTW	
Cleaning of building exteriors which have <b>HAZARDOUS MATERIALS</b> (e.g. mercury, lead) in paints	1. Use dry cleaning methods. 2. Contain and dispose washwater as hazardous waste (Suggestion: dry material first to reduce volume).		
Non-hazardous paint scraping/sand blasting	Dry sweep, dispose as trash.		Dry sweep, dispose as trash.
<b>HAZARDOUS</b> paint scraping/sand blasting (e.g. marine paints or paints containing lead or tributyl tin)	Dry sweep, dispose as hazardous waste.		Dry sweep, take to HHW drop-off.

**TABLE ICP-12-1  
QUICK REFERENCE – DISPOSAL ALTERNATIVES**

DISCHARGE/ACTIVITY	BUSINESS/COMMERCIAL		RESIDENTIAL
	Disposal Priorities	Approval	Disposal Priorities
<b>General Construction and Painting: Street and Utility Maintenance (cont'd.)</b>			
Soil from excavations during periods when storms are forecast	<ol style="list-style-type: none"> <li>1. Should not be placed on paved areas.</li> <li>2. Remove from site or backfill by end of day.</li> <li>3. Cover with tarpaulin or surround with silt fences, or use other runoff controls.</li> <li>4. Place filter mat over storm drain.</li> </ol>		
Soil from excavations placed on paved surfaces during periods when storms are not forecast	Keep material out of storm conveyance systems and thoroughly remove via sweeping following removal of dirt.		
Cleaning streets in construction areas	<ol style="list-style-type: none"> <li>1. Dry sweep and minimize tracking of mud.</li> <li>2. Use silt ponds and/or similar pollutant reduction techniques when flushing pavement.</li> </ol>		
Soil erosion, sediments	<ol style="list-style-type: none"> <li>1. Cover disturbed soils, use erosion controls, block entry to storm drain.</li> <li>2. Seed or plant immediately.</li> </ol>		
Fresh cement, grout, mortar	<ol style="list-style-type: none"> <li>1. Use/reuse excess</li> <li>2. Dispose to trash</li> </ol>		<ol style="list-style-type: none"> <li>1. Use/reuse excess</li> <li>2. Dispose to trash</li> </ol>
Washwater from concrete/mortar (etc.) cleanup	<ol style="list-style-type: none"> <li>1. Wash onto dirt area, spade in.</li> <li>2. Pump and remove to appropriate disposal facility.</li> <li>3. Settle, pump water to sanitary sewer.</li> </ol>	POTW	<ol style="list-style-type: none"> <li>1. Wash onto dirt area, spade in.</li> <li>2. Pump and remove to appropriate disposal facility.</li> <li>3. Settle, pump water to sanitary sewer.</li> </ol>
Aggregate wash from driveway/patio construction	<ol style="list-style-type: none"> <li>1. Wash onto dirt area, spade in.</li> <li>2. Pump and remove to appropriate disposal facility.</li> <li>3. Settle, pump water to sanitary sewer.</li> </ol>	POTW	<ol style="list-style-type: none"> <li>1. Wash onto dirt area, spade in.</li> <li>2. Pump and remove to appropriate disposal facility.</li> <li>3. Settle, pump water to sanitary sewer.</li> </ol>
Rinsewater from concrete mixing trucks	<ol style="list-style-type: none"> <li>1. Return truck to yard for rinsing into pond or dirt area.</li> <li>2. At construction site, wash into pond or dirt area.</li> </ol>		
Non-hazardous construction and demolition debris	<ol style="list-style-type: none"> <li>1. Recycle/reuse (concrete, wood, etc.).</li> <li>2. Dispose as trash.</li> </ol>		<ol style="list-style-type: none"> <li>1. Recycle/reuse (concrete, wood, etc.).</li> <li>2. Dispose as trash.</li> </ol>
Hazardous demolition and construction debris (e.g. asbestos)	Dispose as hazardous waste.		Do not attempt to remove yourself. Contact asbestos removal service for safe removal and disposal. Very small amounts (less than 5 lbs.) may be double-wrapped in plastic and taken to HHW drop-off.

**TABLE ICP-12-1  
QUICK REFERENCE – DISPOSAL ALTERNATIVES**

DISCHARGE/ACTIVITY	BUSINESS/COMMERCIAL		RESIDENTIAL
	Disposal Priorities	Approval	Disposal Priorities
<b>General Construction and Painting: Street and Utility Maintenance (cont'd.)</b>			
Saw-cut slurry	<ol style="list-style-type: none"> <li>1. Use dry cutting technique and sweep up residue.</li> <li>2. Vacuum slurry and dispose off-site.</li> <li>3. Block storm drain or berm with low weir as necessary to allow most solids to settle. Shovel out gutters; dispose residue to dirt area, construction yard or landfill.</li> </ol>		
Construction dewatering (Nonturbid, uncontaminated groundwater)	<ol style="list-style-type: none"> <li>1. Recycle/reuse.</li> <li>2. Discharge clear water to storm drain.</li> </ol>		
Construction dewatering (Other than nonturbid, uncontaminated groundwater)	<ol style="list-style-type: none"> <li>1. Recycle/reuse.</li> <li>2. Discharge to sanitary sewer.</li> <li>3. As appropriate, treat prior to discharge to storm drain.</li> </ol>	POTW  HCWQP	
Portable toilet waste	Leasing company shall dispose to sanitary sewer at POTW.	POTW	
Leaks from garbage dumpsters	<ol style="list-style-type: none"> <li>1. Collect, contain leaking material. Eliminate leak, keep covered, return to leasing company for immediate repair.</li> <li>2. If dumpster is used for liquid waste, use plastic liner.</li> </ol>		
Leaks from construction debris bins	Insure that bins are used for dry nonhazardous materials only (Suggestion: Fencing, covering help prevent misuse).		
Dumpster cleaning water	<ol style="list-style-type: none"> <li>1. Clean at dumpster owner's facility and discharge waste through grease interceptor to sanitary sewer.</li> <li>2. Clean on site and discharge through grease interceptor to sanitary sewer.</li> </ol>	POTW  POTW	
Cleaning driveways, paved areas (Special Focus = Restaurant alleys, grocery dumpster areas)	<ol style="list-style-type: none"> <li>1. Sweep and dispose as trash (Dry cleaning only).</li> <li>2. For vehicle leaks, restaurant/grocery alleys, follow this 3-step process: <ol style="list-style-type: none"> <li>a. Clean up leaks with rags or absorbents.</li> <li>b. Sweep, using granular absorbent material (cat litter).</li> <li>c. Mop and dispose of mopwater to sanitary.</li> </ol> </li> </ol>		<ol style="list-style-type: none"> <li>1. Sweep and dispose as trash (Dry cleaning only).</li> <li>2. For vehicle leaks follow this 3-step process: <ol style="list-style-type: none"> <li>a. Clean up leaks with rags or absorbents; dispose as hazardous waste.</li> <li>b. Sweep, using granular absorbent material (cat litter).</li> <li>c. Mop and dispose of mopwater to sanitary sewer.</li> </ol> </li> </ol>

**TABLE ICP-12-1  
QUICK REFERENCE – DISPOSAL ALTERNATIVES**

DISCHARGE/ACTIVITY	BUSINESS/COMMERCIAL		RESIDENTIAL
	Disposal Priorities	Approval	Disposal Priorities
<b>General Construction and Painting: Street and Utility Maintenance (cont'd.)</b>			
Steam cleaning of sidewalks, plazas	<ol style="list-style-type: none"> <li>1. Collect all water and pump to sanitary sewer.</li> <li>2. Follow this 3-step process:               <ol style="list-style-type: none"> <li>a. Clean oil leaks with rags or adsorbents.</li> <li>b. Sweep up dispose in trash (Use dry absorbent as needed).</li> <li>c. Use no soap, discharge to storm drain.</li> </ol> </li> </ol>		
Potable water/line flushing Hydrant testing	Deactivate chlorine by maximizing time water will travel before reaching creeks.		
Super-chlorinated (above 1 ppm) water from line flushing	<ol style="list-style-type: none"> <li>1. Discharge to sanitary sewer.</li> <li>2. Complete dechlorination required before discharge to storm drain.</li> </ol>		
<b>LANDSCAPE/GARDEN MAINTENANCE</b>			
Pesticides	<ol style="list-style-type: none"> <li>1. Use up. Rinse containers, use rinsewater as product. Dispose rinsed containers as trash.</li> <li>2. Dispose unused pesticide as hazardous waste.</li> </ol>		<ol style="list-style-type: none"> <li>1. Use up. Rinse containers, use rinsewater as pesticide. Dispose rinsed container as trash.</li> <li>2. Take unused pesticide to HHW drop-off.</li> </ol>
Garden clippings	<ol style="list-style-type: none"> <li>1. Compost.</li> <li>2. Take to Landfill.</li> </ol>		<ol style="list-style-type: none"> <li>1. Compost.</li> <li>2. Dispose as trash.</li> </ol>
Tree trimming	Chip if necessary, before composting or recycling.		Chip if necessary, before composting or recycling.
Swimming pool, spa, fountain water (emptying)	<ol style="list-style-type: none"> <li>1. Do not use metal-based algicides (i.e. Copper Sulfate).</li> <li>2. Recycle/reuse (e.g. irrigation).</li> <li>3. Determine chlorine residual = 0, wait 24 hours and then discharge to storm drain.</li> </ol>	POTW	<ol style="list-style-type: none"> <li>1. Do not use metal-based algicides (i.e. Copper Sulfate).</li> <li>2. Recycle/reuse (e.g. irrigation).</li> <li>3. Determine chlorine residual = 0, wait 24 hours and then discharge to storm drain.</li> </ol>
Acid or other pool/spa/fountain cleaning	Neutralize and discharge to sanitary sewer.	POTW	
Swimming pool, spa filter backwash	<ol style="list-style-type: none"> <li>1. Reuse for irrigation.</li> <li>2. Dispose on dirt area.</li> <li>3. Settle, dispose to sanitary sewer.</li> </ol>		<ol style="list-style-type: none"> <li>1. Use for landscape irrigation.</li> <li>2. Dispose on dirt area.</li> <li>3. Settle, dispose to sanitary sewer.</li> </ol>
<b>VEHICLE WASTES</b>			
Used motor oil	Use secondary containment while storing, send to recycler.		<ol style="list-style-type: none"> <li>1. Put out for curbside recycling pick up where available.</li> <li>2. Take to Recycling Facility or auto service facility with recycling program.</li> <li>3. Take to HHW events accepting motor oil.</li> </ol>

**TABLE ICP-12-1  
QUICK REFERENCE – DISPOSAL ALTERNATIVES**

DISCHARGE/ACTIVITY	BUSINESS/COMMERCIAL		RESIDENTIAL
	Disposal Priorities	Approval	Disposal Priorities
<b>Vehicle Wastes (Cont.)</b>			
Antifreeze	Use secondary containment while storing, send to recycler.		Take to Recycling Facility.
Other vehicle fluids and solvents	Dispose as hazardous waste.		Take to HHW event.
Automobile batteries	<ol style="list-style-type: none"> <li>1. Send to auto battery recycler.</li> <li>2. Take to Recycling Center.</li> </ol>		<ol style="list-style-type: none"> <li>1. Exchange at retail outlet.</li> <li>2. Take to Recycling Facility or HHW event where batteries are accepted.</li> </ol>
Motor home/construction trailer waste	Use holding tank. Dispose to sanitary sewer.		Use holding tank, dispose to sanitary sewer.
Vehicle washing	<ol style="list-style-type: none"> <li>1. Recycle.</li> <li>2. Discharge to sanitary sewer, never to storm drain.</li> </ol>	POTW	<ol style="list-style-type: none"> <li>1. Take to Commercial Car Wash.</li> <li>2. Wash over lawn or dirt area.</li> <li>3. If soap is used, use a bucket for soapy water and discharge remaining soapy water to sanitary sewer.</li> </ol>
Mobile vehicle washing	Collect washwater and discharge to sanitary sewer.	POTW	
Rinsewater from dust removal at new car fleets	<ol style="list-style-type: none"> <li>1. Discharge to sanitary sewer.</li> <li>2. If rinsing dust from exterior surfaces for appearance purposes, use no soap (water only); discharge to storm drain.</li> </ol>	POTW	
Vehicle leaks at Vehicle Repair Facilities	Follow this 3-step process: <ol style="list-style-type: none"> <li>1. Clean up leaks with rags or absorbents.</li> <li>2. Sweep, using granular absorbent material (cat litter).</li> <li>3. Mop and dispose of mopwater to sanitary sewer.</li> </ol>		
<b>Other Wastes</b>			
Carpet cleaning solutions & other mobile washing services	Dispose to sanitary sewer.	POTW	Dispose to sanitary sewer.
Roof drains	<ol style="list-style-type: none"> <li>1. If roof is contaminated with industrial waste products, discharge to sanitary sewer.</li> <li>2. If no contamination is present, discharge to storm drain.</li> </ol>		
Cooling water Air conditioning condensate	<ol style="list-style-type: none"> <li>1. Recycle/reuse.</li> <li>2. Discharge to sanitary sewer.</li> </ol>	POTW	
Pumped groundwater, infiltration/foundation drainage (contaminated)	<ol style="list-style-type: none"> <li>1. Recycle/reuse (landscaping, etc.)</li> <li>2. Treat if necessary; discharge to sanitary sewer.</li> </ol>	HCWQP  POTW	

**TABLE ICP-12-1  
QUICK REFERENCE – DISPOSAL ALTERNATIVES**

DISCHARGE/ACTIVITY	BUSINESS/COMMERCIAL		RESIDENTIAL
	Disposal Priorities	Approval	Disposal Priorities
	3. Treat and discharge to storm drain.	HCWQP	
Firefighting flows	If contamination is present, Fire Dept. will attempt to prevent flow to stream or storm drain.		
Kitchen Grease	<ol style="list-style-type: none"> <li>1. Provide secondary containment, collect, send to recycler.</li> <li>2. Provide secondary containment, collect, send to POTW via hauler.</li> </ol>	POTW	1. Collect, solidify, dispose as trash.
Restaurant cleaning of floor mats, exhaust filters, etc.	<ol style="list-style-type: none"> <li>1. Clean inside building with discharge through grease trap to sanitary sewer.</li> <li>2. Clean outside in container or bermed area with discharge to sanitary sewer.</li> </ol>		
Clean-up wastewater from sewer back-up	<ol style="list-style-type: none"> <li>1. Follow this procedure:               <ol style="list-style-type: none"> <li>a. Block storm drain, contain, collect, and return spilled material to the sanitary sewer.</li> <li>b. Block storm drain, rinse remaining material to collection point and pump to sanitary sewer (no rinsewater may flow to storm drain).</li> </ol> </li> </ol>		





**This page intentionally left blank**

---