



*Development Resource Center
1250 Market Street, Suite 3050
Chattanooga, TN 37402
Tel: 423-209-7842
Fax: 423-209-7843*

*Cleveland T. Grimes
Executive Director*

September 20, 2010

TO WHOM IT MAY CONCERN:

All plastic pipe used in constructing private service laterals for Hamilton County WWTA customers shall meet or exceed pressure rated Schedule 40 pipe. Service laterals shall be supported by six (6) inches of 1/2" washed stone, and the pipe shall be covered by twelve (12) inches of 1/2" washed stone (See Standard Details SD-15 and SD-16). Additionally, if any portion of the pipe is required to be constructed under pavement, the pipe under the pavement and the last three (3) feet of the line, from the pavement edge, shall be bedded and totally backfilled with crusher run stone (See Standard Detail SD-9). If a cleanout is required in the paved area, the cleanout will be protected as shown in Standard Detail SD-17.

Private service laterals constructed within the WWTA service area shall be air tested as required by Section 312 of the International Plumbing Code approved by the Hamilton County Building Inspection Department. The laterals shall hold 5 psi for 5 minutes.

A Closed Circuit Television (CCTV) video for newly constructed service lateral must be submitted to the WWTA before the private service lateral will be accepted. The CCTV video will require the following:

- A camera - capable of producing color digital video;
- Exact footage – with title on video (or text heading);
- Video titler system will have capability of inputting on screen defect codes, and all applicable site information (including Date, Plumber, Lot # & Address);
- Digital video is to be non-pixelated (i.e. contain no digital distortion and be sharp-demonstrating precise shape and color of the pipe-lines and defects);
- Defects must be easily recognizable and defined;
- Recorded video must be compatible with DVD recordable formats or flash drives and viewable on a standard 21" LCD monitor or a 30" television; and
- Video will not be accepted until final inspection just prior to Certificate of Occupancy.

NOTE: Testing and video recording will occur at Final Inspection. The plumber may choose to perform testing and video work prior to a request for inspection, at their own choosing.

A private service lateral shall not be **connected** to the WWTA sewer system (gravity, grinder, step, or small diameter) until the structure is ready for **FINAL INSPECTION** by the Hamilton County or City Building Department, without prior approval from the Wastewater Manager. If the service lateral is **installed** before the structure is ready for final inspection, a gap must be left in the service lateral somewhere between five (5) feet from the structure and the connection at the sewer main. The gap must be removed at final inspection of the structure before the service lateral can be given final approval.

NOTE: A specific appointment may not be requested on a first inspection (the Resident Project Representative (RPR) has a twenty-four (24)-hour notice called in by the plumber at WWTA (423) 209-7842). The entire lateral must be exposed at the first inspection.

NOTE: All service lateral installations and connections must be inspected and approved by the Wastewater Manager or authorized representative (RPR) before the line is backfilled.

NOTE: No service lateral connection shall be made to a sewer that has not been accepted by the Hamilton County WWTA.

NOTE: Change of direction: No greater than a forty-five (45)-degree bend shall be installed at each change of direction of the private service lateral.

A double cleanout shall be provided at the discharge point on the outside private service lateral of the house, and a double cleanout shall be provided on the private service lateral at the property line between the public sewer and the structure being connected (See Standard Details SD-15 and SD-16). Other cleanouts shall be provided in accordance with the governing plumbing code.

NO FERNCO FITTINGS (or other flexible fittings) shall be used for new or the repair of private service laterals.

It is recommended that the private service lateral be located ten (10) feet from any water line. In no case should the private service lateral be located within five (5) feet of a water line, once the lines are five (5) feet from the structure. If the sewer line crosses the water line, it is recommended that the private service lateral be located eighteen (18) inches below the water line. In no case should the private service lateral be located less than twelve (12) inches of separation below the water line.

Once the private service lateral is five (5) feet from the building, the line must be a minimum of twenty four (24) inches below the present surface of the yard, with the tie-in at the service stub-out a minimum of thirty (30) inches.

When it is impractical to obtain proper horizontal or vertical separation or depth, the Wastewater Manager shall be contacted, prior to construction of the private service lateral. In the event of reduced separation, additional testing of the private service lateral may be required to insure water-tightness.

Cleanouts located under an area used as a drive shall have a six (6)-inch cast iron box and "SEWER" lid located over the recessed four (4)-inch service lateral riser and cap to prevent damage from vehicular traffic.

Do not hesitate to call our office at (423) 209-7842 should you have any questions.

Sincerely,



Cleveland T. Grimes
Executive Director

Enclosures: SD-GEN-9
SD-GEN-15
SD-GEN-16
SD-GEN-17
Section 2731

GENERAL REQUIREMENTS

1. ALL STREET CUTS MUST BE REPAIRED IMMEDIATELY AFTER BACKFILLING AND ACCORDING TO THIS STANDARD.
2. A ROAD CUT PERMIT AND AN APPROVED TRAFFIC CONTROL PLAN ARE REQUIRED FOR ALL CUTS IN STREETS.
3. WHERE LONGITUDINAL CUTS ARE MADE, THE OWNER RESERVES THE RIGHT TO REQUIRE ADDITIONAL RESURFACING BEYOND THE LIMITS OF THE REPAIR TO ENSURE THE PROPER RIDING CHARACTERISTICS AND THE STABILITY OF THE PAVEMENT.

DRAWING NOTES

- ① CLASS "A" CONCRETE PAVEMENT (4,000 PSI MINIMUM), 8" MINIMUM THICKNESS, COARSE BROOM FINISH THE CONCRETE SHALL BE COLORED AND STAMPED TO MATCH THE ADJACENT CONCRETE AS REQUIRED.
- ② MINERAL AGGREGATE BASE, TYPE A, GRADING D (33-P*) COMPACTED IN 8" LIFTS AND TO A DENSITY OF 95% STANDARD PROCTOR.
- ③ BEDDING MATERIAL - SEE SD-GEN-1
- ④ MINERAL AGGREGATE BASE, TYPE A, GRADING D (33-P*) COMPACTED TO A DENSITY OF 95% STANDARD PROCTOR. THE THICKNESS SHALL BE THE GREATER OF 4" OR THE EXISTING DEPTH OF BASE MATERIAL.

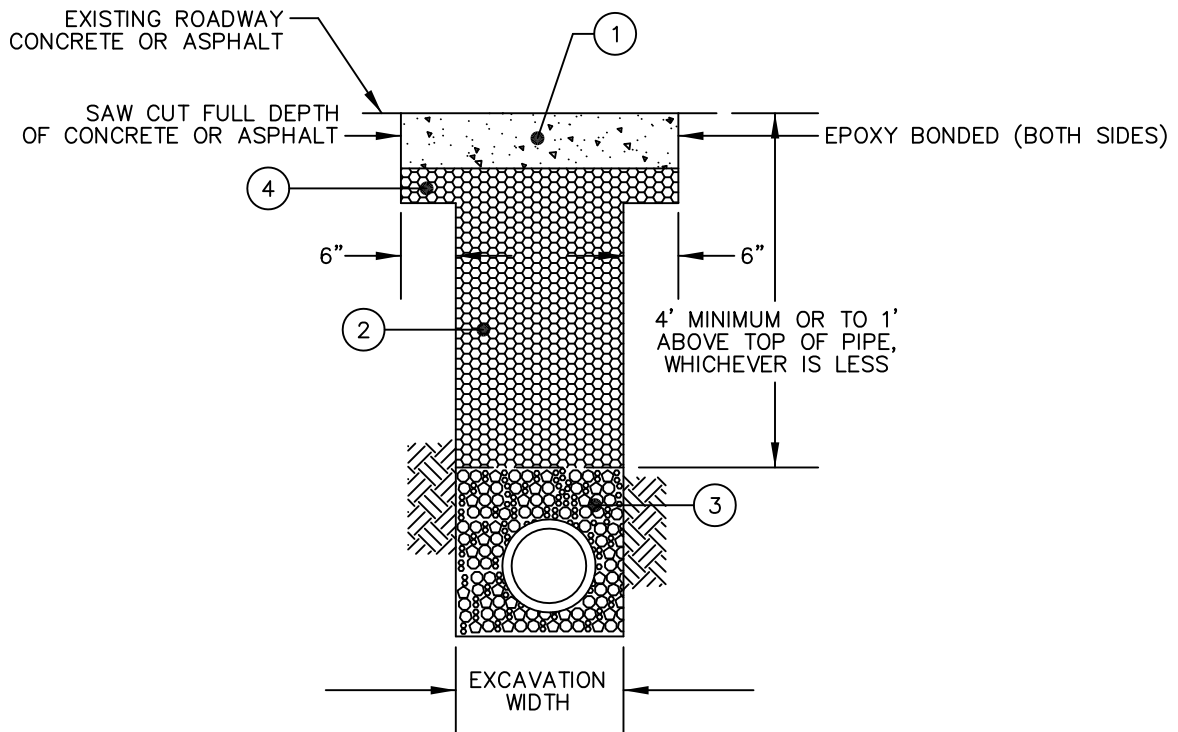

TRENCH WIDTH PAVEMENT REPAIR

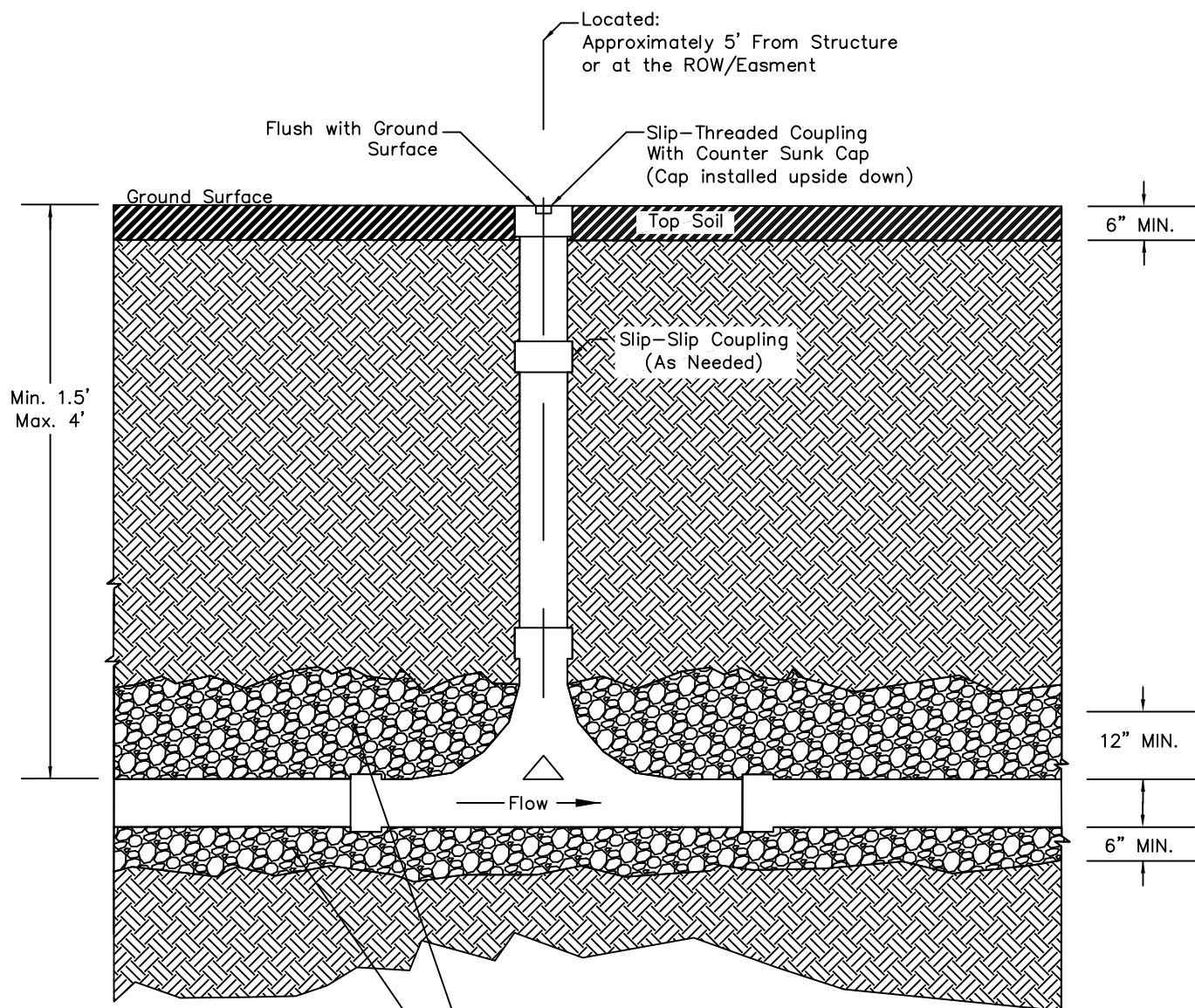

TRENCH BEDDING (CLASS "1", ASTM D 2321)
MATERIAL SHALL BE 1/2 INCH WASHED STONE.

SERVICE CONNECTION SHALLOW CLEANOUT (TYPICAL)

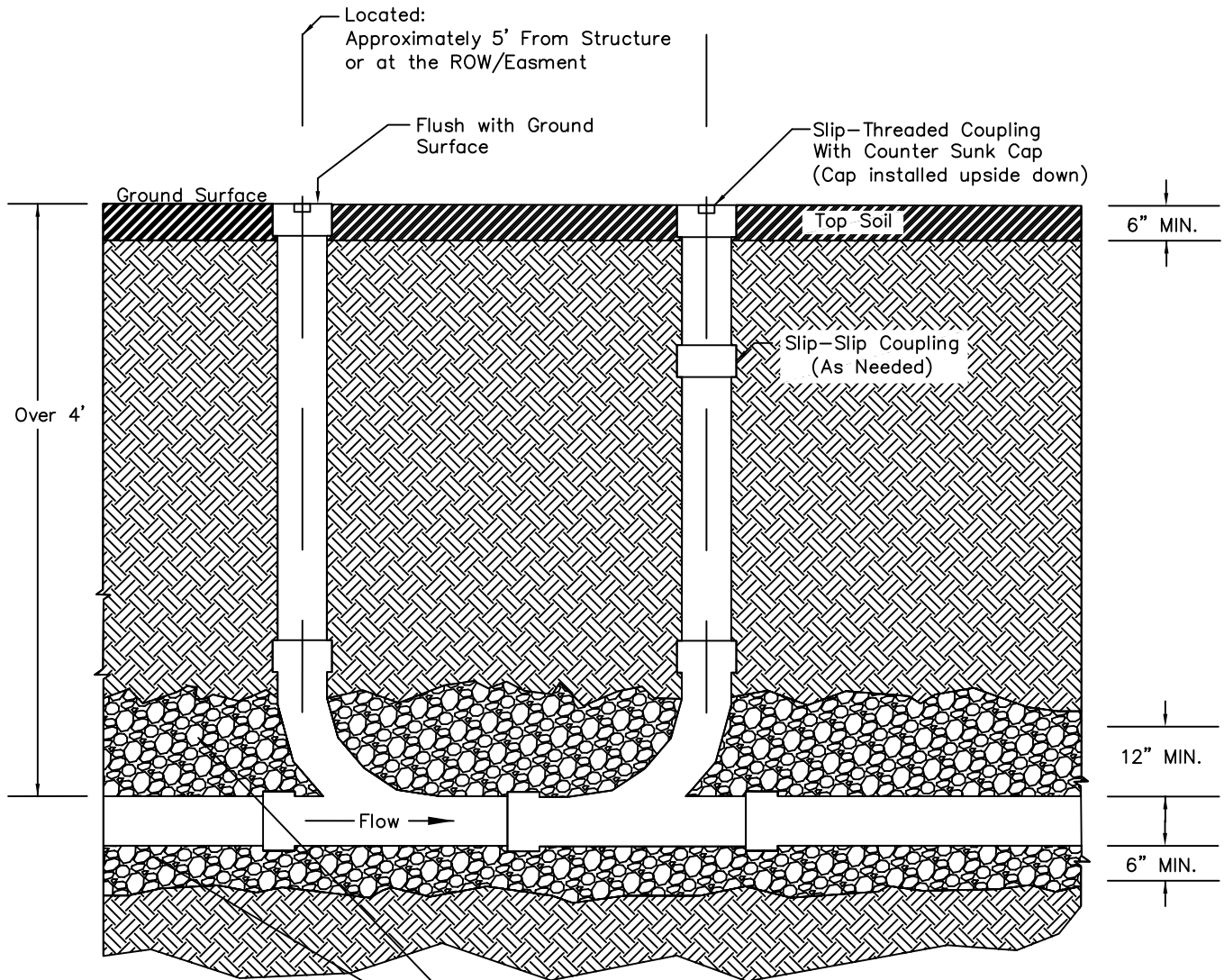

TRENCH BEDDING (CLASS "1", ASTM D 2321)
 MATERIAL SHALL BE 1/2 INCH WASHED STONE.

Note: The sweeps should be constructed to avoid a "blind spot" in the lateral.

SERVICE CONNECTION DEEP CLEANOUT (TYPICAL)

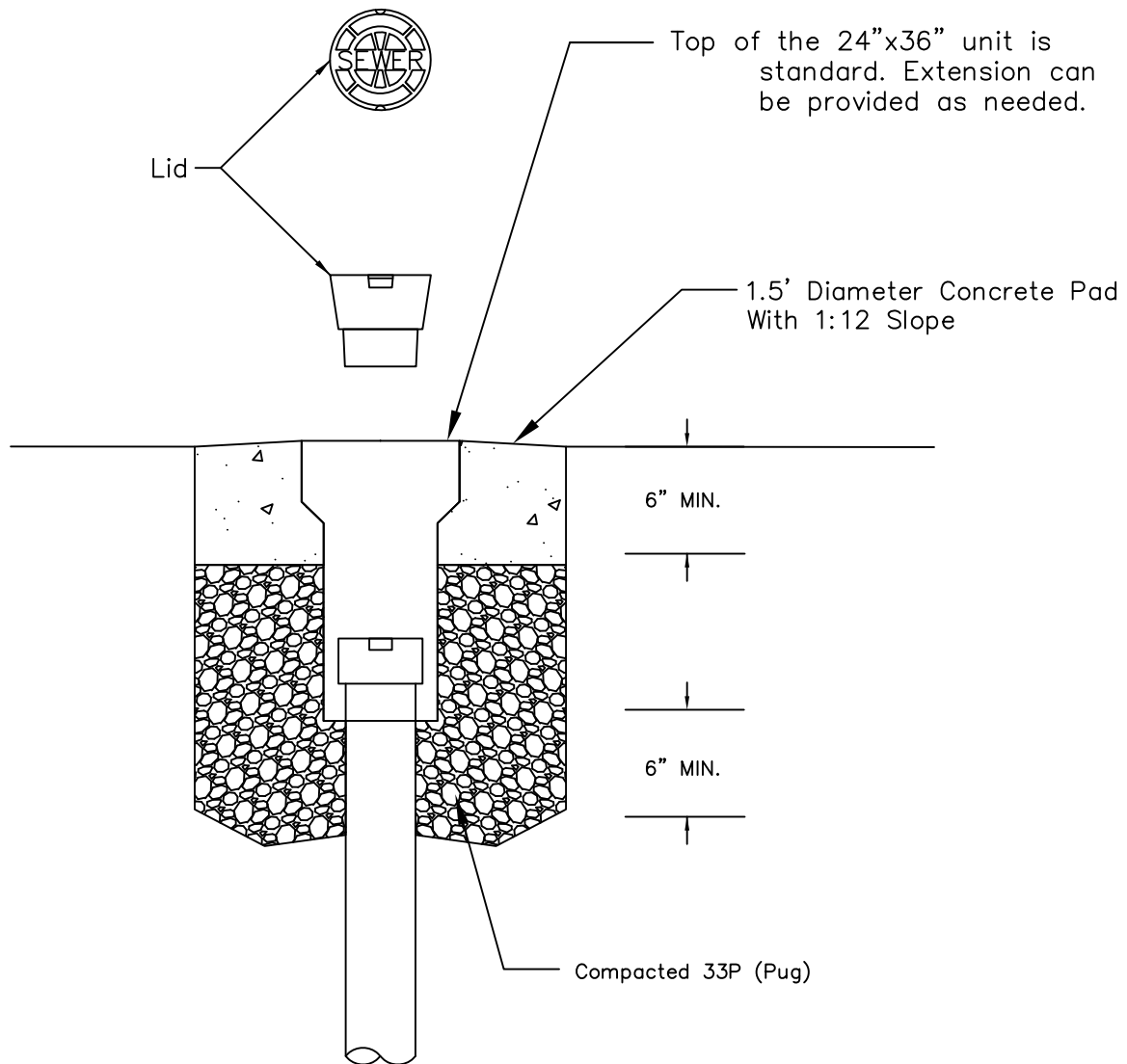

Note: This detail is used for cleanouts required at drives and roadways. If the cleanout can be shifted to avoid a driveway or roadway, it should be.

CAST IRON TWO-PIECE ADJUSTABLE VALVE BOX (TYPICAL)

HAMILTON COUNTY WATER & WASTEWATER TREATMENT AUTHORITY
SD-GEN-17

SECTION 02731
POLYVINYL CHLORIDE (PVC) GRAVITY SEWER AND SERVICE PIPE

PART 1 - GENERAL

1.01 SCOPE

The work covered by this section includes furnishing all labor, equipment, and materials required to install and test polyvinyl chloride (PVC) pipe, including accessories, as shown on the Drawings and/or specified herein.

1.02 QUALITY ASSURANCE

- A. The Master Plumber, at the Engineer's request, shall furnish a certificate from the manufacturer of the pipe and fittings that the manufacturer is fully competent and capable of manufacturing PVC sewer pipe, fittings, and accessories of uniform texture and strength that will fully comply with these Specifications and have so manufactured this class of pipe in sufficient quantities to be certain that it will meet all normal field conditions of usage. The manufacturer must have adequate equipment and quality control facilities to be sure that each extrusion of pipe is uniform in texture, dimensions, and strength.
- B. Pipe shall be tested when requested by the Engineer, or the Engineer's Resident Project Representative (RPR), and all pipe, so designated, shall be tested in accordance with ASTM D 2412 "Standard Method of Test for External Loading Properties of Plastic Pipe by Parallel Plate Loading."
- C. Each length of pipe and each fitting shall have the following data clearly marked on each piece:
 - 1. Manufacturer's name or trademark
 - 2. Manufactured date
 - 3. Nominal pipe size
 - 4. PVC compound used
 - 5. ASTM material code designation
 - 6. ASTM specification designation

This text should be set so that it is visible to the RPR at the time of observation (i.e. the text should be facing up when the pipe is set in the trench.)

1.03 SHOP DRAWINGS AND ENGINEERING DATA

Complete shop drawings and engineering data shall be submitted to the Engineer in accordance with the requirements of the Section 1300, "Submittals" of these Specifications.

1.04 STORAGE AND PROTECTION

- A. PVC pipe and fittings shall be stored under black plastic cover.
- B. All pipe and accessories shall be stored aboveground and fully supported so as not to bend or deflect excessively under its own weight.

1.05 GUARANTEE

The Master Plumber shall provide a guarantee against defective equipment and workmanship in accordance with the requirements of the Section 01340, "Guarantees and Warranties" of these Specifications.

PART 2 - PRODUCTS

2.01 PVC PIPE AND FITTINGS

- A. The pipe and fittings shall be homogeneous throughout and free from visible cracks, holes, foreign inclusions, or other injurious defects. The pipe shall be as uniform as commercially practical in color, opacity, density, and other physical properties.
- B. The manufacturer shall provide waterstops, acceptable to the Engineer, which shall be applied to the outside of the plastic pipe when the pipe is to be enclosed in any structure where concrete or mortar is used which will prevent leakage along the outer wall of the barrel of the pipe.
- C. No single piece of pipe shall be laid on any project covered by this Specification unless it is found to be generally straight. Such pipe shall have a maximum ordinate as measured from the concave side of the pipe not to exceed 1/16 inch per foot of length. If the deviation exceeds this requirement, then the particular piece of pipe shall be rejected from the use until it can comply with this provision.
- D. Wyes, tees, bends, adapters, and any other fittings required shall be provided. Engineering data for such fittings showing cross-sectional views with dimensions shall be provided and such data and fittings shall be approved by the Engineer prior to their use. The materials used in the manufacture of fittings shall conform to the requirements for the pipe with which they shall be used and any variation of such requirements shall be subject to the approval of the Engineer. Fittings shall have wall thickness equal to or greater than that of the pipe to which they are joined.

2.02 PIPE

- A. PVC piping and accessories shall be made from Virgin Type I, Grade 1 PVC compounds with physical and chemical properties conforming to those defined and described in ASTM D 1784 for "Rigid Poly (Vinyl Chloride) Compounds and Chlorinated Poly (Vinyl Chloride) Compounds".

- B. The PVC pipe and accessories shall be manufactured in accordance with the requirements of ASTM D 3034, Type PSM Polyvinyl Chloride (PVC) Sewer Pipe and Fittings.
- C. Pipe for service lines and house connections:
 - 4-inch diameter shall be Schedule 40.
 - 6-inch diameter shall be Schedule 40. Schedule 35 may be approved.
- D. Pipe and fittings shall be made from polyvinyl chloride compounds, which comply, with the requirements for a minimum cell classification of 12364A as defined by ASTM D-1784.

2.03 JOINTS

- A. PVC pipe joints for service laterals shall be solvent weld/glue. Solvent cements shall meet the requirements of ASTM D-2564.

PART 3 - EXECUTION

3.01 PIPE INSTALLATION

- A. In accordance with ASTM D-2321.
- B. Pipe will be placed in the trench so that the required text is up.
- C. Before sewer pipe is placed into position in the trench the bottom and sides of the trench shall be carefully prepared and bracing and sheeting installed where required. Each pipe shall be accurately placed to the exact line and grade called for on the Drawings.
- D. The Master Plumber shall ensure that the lateral is sloped in accordance with Section 704 of the International Building Code.
- E. The Master Plumber will inspect each piece of pipe and special fitting carefully before it is placed and no defective pipe shall be laid in the trench. Pipe laying shall proceed upgrade, starting at the lower end of the grade. No pipe shall be covered until observed by an RPR. Trench bottoms found to be unsuitable for foundations after pipe laying operations have started shall be corrected and brought to exact line and grade with approved compacted materials.
- F. Bell holes shall be of sufficient size to allow ample room for making the pipe joints properly. Bell holes shall not be cut out more than ten joints ahead of pipe laying. The bottom of the trench between bell holes shall be carefully graded so that the pipe barrel will rest on a solid foundation for its entire length as shown on the Drawings. Each joint shall be laid so that it will form a close concentric joint with adjoining pipe in order to avoid sudden offsets or inequalities in the flow line.

- G. Water shall not be allowed to run or stand in the trench while pipe laying is in progress or before the joints are completely set or before the trench has been backfilled. At no time shall the Master Plumber open up more trench than his available pumping facilities are able to dewater.
- H. No joints shall be made where pipe or joint materials have been soiled by earth in handling until such soiled surfaces are thoroughly cleaned by wire brushing and wiping until all traces of the earth are removed.
- I. As the work progresses, the interior of all pipe shall be kept thoroughly clean. After each line of pipe has been laid, it shall be carefully inspected and all earth, trash, rags, and other foreign matter removed from the interior.
- J. Backfilling of trenches shall be started immediately after the pipe in place has been inspected and approved by the Engineer or his inspector and backfill shall be deposited and compacted as provided in Section 3.02 below – Installation of Service Pipe and Tees.

3.02 INSTALLATION OF SERVICE PIPE AND TEES

- A. Installation of service pipe shall conform to the appropriate requirements as shown on the drawings, including SD-GEN-15, SD-GEN-16, and SD-GEN-17.
- B. Connections of service lines to the main sewer if required shall be made with bends of the proper degree to make the service run perpendicular to the main sewer. No greater than a 45-degree bend shall be installed at each change of direction of the sewer service lateral. Pipe shall be laid to a uniform line and grade. Minimum grade shall be 1 percent.
- C. A double clean out shall be provided at the discharge point on the outside sewer service line of the house, and a double clean out shall be provided on the sewer service line at the property line between the public sewer and the structure being connected. Other clean outs shall be provided in accordance with the governing plumbing code.
- D. When a service line is installed under the roadway, it shall be backfilled with stone. The top three (3) feet shall be backfilled with crusher run (33P) stone and the last three (3) feet of the line, from the pavement edge, shall be bedded and totally backfilled with ½ inch washed stone (See Standard Detail SD-GEN-9).
- E. When a new service line is installed to connect an existing building sewer; when the building sewer is cast iron, concrete, or clay, a Fernco fitting may be approved. Otherwise, NO FERNCO FITTINGS (or other flexible fittings) shall be used for new or the repair of private service laterals.
- F. Service lines shall be bedded and supported completely with washed stone 6” under and 12” over the pipe.

- G. If the sewer service line crosses a water line, there shall be a minimum of 18-inches between the top of the bottom pipe and the bottom of the top pipe.
- H. When it is impractical to obtain proper horizontal or vertical separation or depth, the WWTa shall be contacted, prior to replacing the sewer service line. In the event of reduced separation, additional testing of the sewer service line may be required to insure water-tightness or additional measures may be required.

3.03 CONNECTIONS

- A. Unauthorized connections as determined by the WWTa shall be disconnected from the service lateral.
- B. When existing service line connections include materials or installation methods other than that which is currently approved by the WWTa, the service line shall be removed and replaced properly with currently approved materials and methods.

3.04 INSPECTION AND TESTING

- A. After completion of any section of sewer, the grades, joints, and alignment shall be true to line and grade. Joint surfaces shall be smooth. There shall be no visual leakage and the sewer shall be completely free from any cracks and from protruding joint materials, deposits of sand, mortar, or other materials on the inside.
- B. All PVC sewer laterals shall be tested using low pressure air testing in accordance with the procedures and standards listed below. Evaluation Contractor shall furnish all supplies, material, labor, services, etc., needed to make the test at no extra cost to the Owner, including an air pressure gauge capable of reading up to 10 psi accurately.
 - 1. Plug all pipe outlets with suitable test plugs. Brace each plug securely to prevent blowouts. As a safety precaution, pressurizing equipment shall include a regulator set at slightly above test pressure to avoid overpressurizing and damaging an otherwise acceptable line.
 - 2. Service laterals shall be tested at 5 psi for 5 minutes.
- C. Any leakage, including active seepage, shall be reported to the WWTa representative for correction by the lateral repair Master Plumber.
- D. All PVC sewer laterals shall be videoed using Close Circuit Television (CCTV). CCTV will require the following: CCTV equipment must possess a color camera capable of producing color digital video with on screen accurate footage and video titler. Color digital video is to be non-pixelated, sharp image, representing the true shape and color of the pipe with defects being easily recognizable and defined on a standard 21" LCD computer monitor, or 30" TV. Digital recorded format should be such that the media file

can be easily viewed through a DVD+/- player or DVD+/- drive on a computer and transferred into the WWTa video storage device. Footage will be displayed on the digital recorded video image. Video titler system will have capability of inputting on screen defect codes, and all applicable site information.

3.05 CLEANUP

- A. After completing each section of the sewer line, the Master Plumber shall remove all debris, construction materials, and equipment from the site of the work, grade and smooth over the surface on both sides of the line and leave the entire construction area in a clean and neat condition. The Master Plumber shall restore all disturbed areas to as good as or better than its original condition. Restoration shall include but not be limited to grassing, replacing shrubbery, trees, fences and other improvements which have been disturbed.
- B. Cleanup and restoration of each yard shall be completed no later than 7 calendar days after each section of sewer line is installed.
- C. Upon final inspection, if any foreign matter is present in the system, flush and clean the sections of line as required.

END OF SECTION 02731